

G3 Display

006 – 00001GF



USER'S MANUAL

Firmware version 1.03.01
Hardware version 1.03

IMPORTANT BASIC-INFORMATION

This User-Manual serves a guideline for safe and effective operation, for installation of equipment and for equipment maintenance. – It is therefore obligatory that all persons who work on or with the equipment are completely familiar with the content of this manual and follow the instructions contained herein. Installation of and work on the product may only be carried out by qualified, authorized and trained staff, familiar with the locally applicable standards and taking into consideration the safety guidelines and measures.

Attention

We from Clayton Power make every effort to ensure that the information contained within this document are correct. However, our equipment is continuously being improved and updated, so we cannot assume liability for any errors which may occur. The information may contain errors or inaccuracies and represents no commitment whatsoever.

Exclusion of liability

Clayton Power shall in no event be liable for loss, damages or costs arising from use of this Clayton Power product, or in any way connected with faulty installation, improper operation or incorrect utilization and maintenance.

Clayton Power shall in no event be liable for any direct or indirect damages, disablement or death on persons who

- works with or are dependent on Clayton Power products
- are connected to medical equipment or to any life support system, where Clayton Power products is integrated as a component

Copyright

The information contained within this document remains the sole property of Clayton Power. No part of this document may be copied or reproduced in any form or by any means, and the information contained within is not to be communicated to a third party, without the prior written consent of Clayton Power.

Clayton Power
Pakhusgården 32
5000 Odense C
Denmark

Phone: +5 46 98 57 60

Table of Contents

- 1 Features 4
- 2 Installation..... 4
 - 2.1 Safety instructions 4
 - 2.2 Wiring..... 4
 - 2.3 Connectors Pinout and Location..... 4
 - 2.4 Connection to system..... 5
- 3 Functions..... 6
 - 3.1 Keyboard function 6
 - 3.2 Main Screen 6
 - 3.3 Menu..... 7
 - 3.3.1 Main menu..... 7
 - 3.3.2 Genset menu 7
- 4 Electrical Specification 9
 - 4.1 Table: General Data..... 9
 - 4.2 Table: Inputs 9
 - 4.3 Table: Output 1-3..... 10
 - 4.4 Table: Remote Output 10
 - 4.5 Table: Single Wire Communication 10
- 5 Label 11
- 6 G3 Display outline drawing 12

1 Features

- Remote control of up to four G3 combi or inverter
- Wide supply voltage range 8-35VDC
- Single wire communication with up to four G3 units
- Low power consumption >5mA in standby mode (without back light)
- Low sleep mode consumption >100uA
- Firmware update over PC

2 Installation

2.1 Safety instructions

Installation must strictly follow the national safety regulations in compliance with the enclosure, mounting, creepage, clearance, casualty, markings, and segregation requirements of the end-use application. The installation must be performed by professional installer only. Switch off the system and check for hazardous voltages before altering any connection! Ensure that both units are switched off during the wiring of G3 display to Inverter/Charger/Combi!

2.2 Wiring

The maximal length of cables between the G3 display 006-00001GF and Inverter/Charger/Combi is 5 meters. Use the wire AWG18 with rating of 300VAC for the connections. The temperature rating of cables has to be minimum 80°C or higher (according to end-use application)

2.3 Connectors Pinout and Location

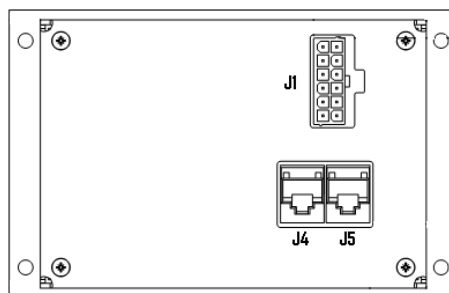

Figure 1: Location of connectors on rear panel of G3 Display

J1	Pin	Signal	Description
		1	GND
	2	GND HALL	Hall sensor ground
	3	+5V HALL	Hall sensor supply
	4	REMOTE OUT	Remote control of G3
	5	+BATTERY	Supply voltage (+ BATTERY)
	6	DATA	Single Wire Data communication
	7	OUT_1	Output #1 – Generator remote control
	8	OUT_2	Output #2
	9	OUT_3	Output #3
	10	SNS HALL	Hall sensor output
	11	INPUT_1	Input #1
	12	INPUT_2	Input #2

Mating connector type is [MOLEX 0039012125](#)

J4, J5	Pin	Signal	Description
		1	-TEMPX1
	2	GND_TELE	User’s GND (Fused)
	3	+TEMPX1	N/A for Display
	4	SYNC_IN/OUT	N/A for Display
	5	DATA	Single Wire Data communication
	6	REMOTE OUT	Remote control of G3

Mating connector type is [MOLEX 0900750031](#)

Connectors J4 and J5 are connected in parallel.

2.4 Connection to system

For connection refer to the **Figure 2** and G3 Display pinout table.

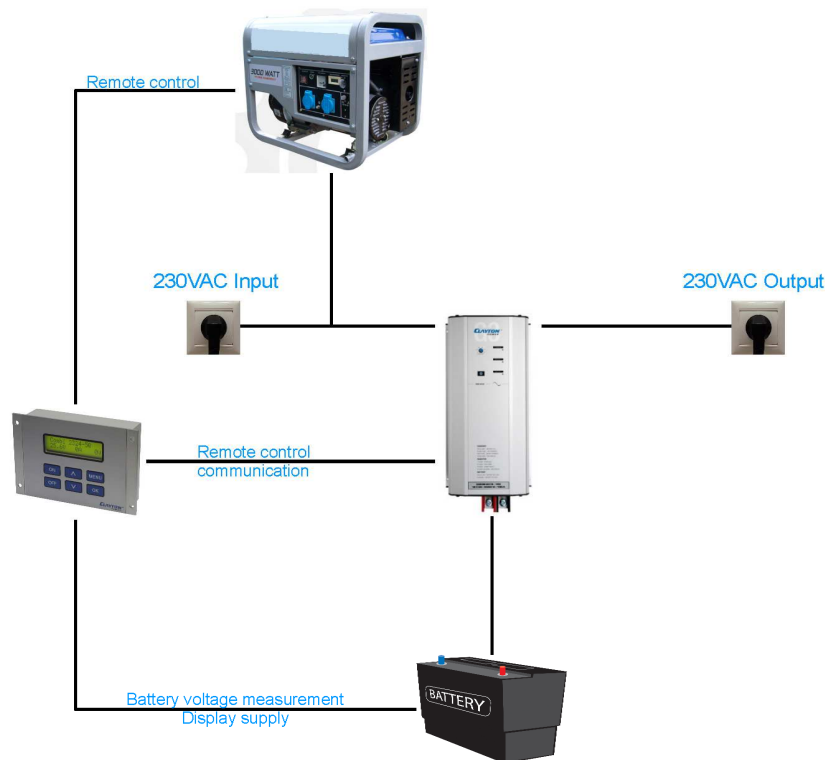





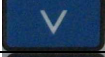

Figure 2:Block connection of G3 Display

3 Functions

G3 Display provides following features:

- ✓ Battery voltage measurement
- ✓ Remote control of connected G3 unit(s)
- ✓ Remote and manual control of generator
- ✓ G3 status information
- ✓ Displaying of battery current
- ✓ Displaying of inverter power
- ✓ Manual control of Boost charge

3.1 Keyboard function

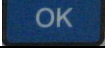
Key	Key Function
	Turn On Display and all connected units
	Turn Off Display and all connected units
	Scroll up in the menu list; increase set value
	Scroll down in the menu list; decrease set value
	Enter to the menu if pressed in main screen or escape from menu if pressed in menu
	Enter to the selected submenu; save set value

3.2 Main Screen

When menu is not active, G3 Display shows following data:

- G3 unit status – charging and inverter mode
- Generator status
- G3 output power
- Measured battery voltage
- Battery current

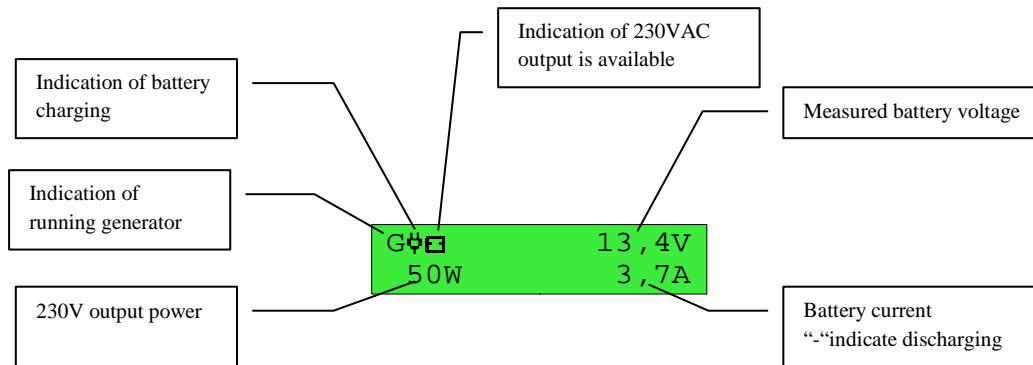

Figure 3: Display main screen description

3.3 Menu

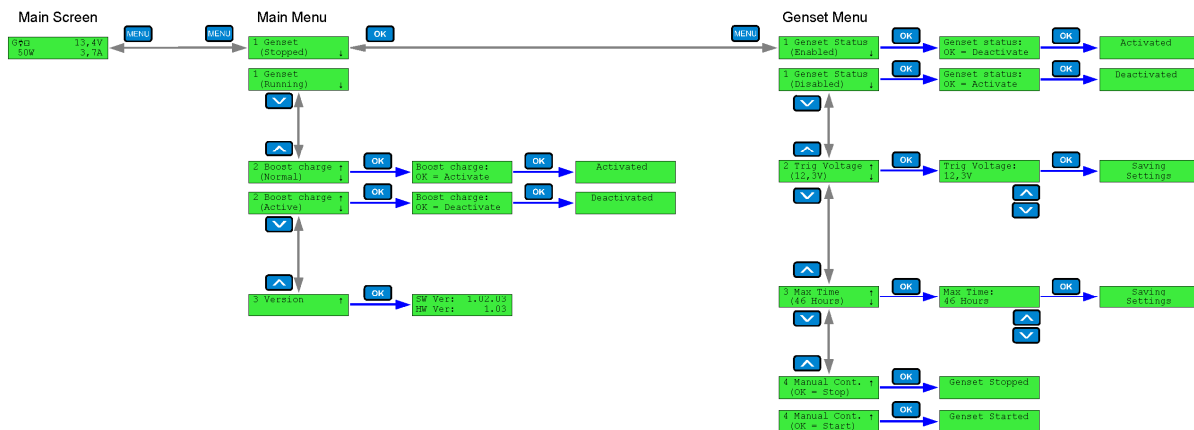

Figure 4: Menu item tree

3.3.1 Main menu

- Boost Charge – During normal charge the Combi charge the battery to 14.4V. When boost mode is active, the Combi charges battery to 15.4V. The Boost mode function is automatically disabled when the 230vac mains grid is removed, making the Combi return to normal charge.

The function is only used on flooded lead acid cells periodically to desulfate the cells. This function should not be used on GEL or AGM batteries.

- Version – shows version of G3 Display firmware and hardware

3.3.2 Genset menu

The Genset function makes it possible to automatically start a Generator when the battery is empty and automatically stops when the battery is full.

The function requires a Combi in the system to handle the 230vac from the generator.

G3 Display 006-00001GF

- Trig Voltage – generator trigger voltage; if the battery voltage is below this voltage, the generator is turned on. The Generator cannot be turned on while the battery voltage is below the trigger level.
- Max Time – maximum period of time the generator is allowed to run if the combi is unable to fully charge the battery within this time. The timer will start to run when the battery voltage is above the voltage trigger level.
- Manual Cont. – manual control of generator. Generator can be controlled manually from trigger voltage until the battery is detected full.
While battery voltage is below Voltage trigger level it is not possible to stop the Generator and while the battery is detected full the generator will be stopped automatically.

4 Electrical Specification

4.1 Table: General Data

G3 Display General Parameters	
Operating voltage	10,2 - 32 VDC
Absolute Voltage rating	8-35 VDC
Normal mode Consumption (@12VDC)	70 mA
Sleep mode Consumption	<5 mA
Operating Temperature	-20°C to 55°C
Storage Temperature	-40°C to 100°C
Dimensions	137 x 43,8 x 88 mm
Weight	285g
Housing	Aluminium case
Connector J1	Molex 39-28-1123
Connector J4 & J5	Molex 95003-2661

Table 4.1 General Data

4.2 Table: Inputs

Input pin 1 & 2	
Input voltage absolute max	32 VDC
“High” level input voltage	>9 VDC
“Low” level input voltage	<4 VDC
Input Impedance	1.8K
Transient protection	By internal diode

Table 4.2 Inputs

4.3 Table: Output 1-3

Output 1 – 3	
Output Topology	Open Collector
Absolute voltage rating	48 VDC
Max sink current	170 mA
Transient protection	By internal diode

Table 4.3 Output 1 - 3

4.4 Table: Remote Output

Remote Output	
Source Voltage	12 VDC
Max Source Current	50 mA
Output Impedance	100 Ω
Transient protection	By internal diode

Table 4.4 Remote Output

4.5 Table: Single Wire Communication

Single Wire Communication	
Output Voltage	12 VDC
Max source current (limited)	450 mA
Internal pull up resistor	1K
Fuse rating	500mAT
Transient protection	By internal diode
Communication Topology	Simplex USART (0-12v)
Communication Speed	9600 baud
Communication protocol	Clayton Power Single Wire rev2.1D

Table 4.5 Single Wire Communication

5 Label

FG006-00001GF ClaytonPower database finnish good number
 BARCODE - Code 39, without check digit

Bxxxxx - Batch Number - *006002*
 SNyyyy - Serial Number - *from 001 to 050*
 Rzzz - Revision Number - *001*
 Yaaaa - Date Code (Example: Y0922 = year 2009, week 22) - *0930*
 hh - Production location code (SK-Slovakia, CZ-Czech Republic, CH-China) - *SK*
 BARCODE - Code 39, without check digit



6 G3 Display outline drawing

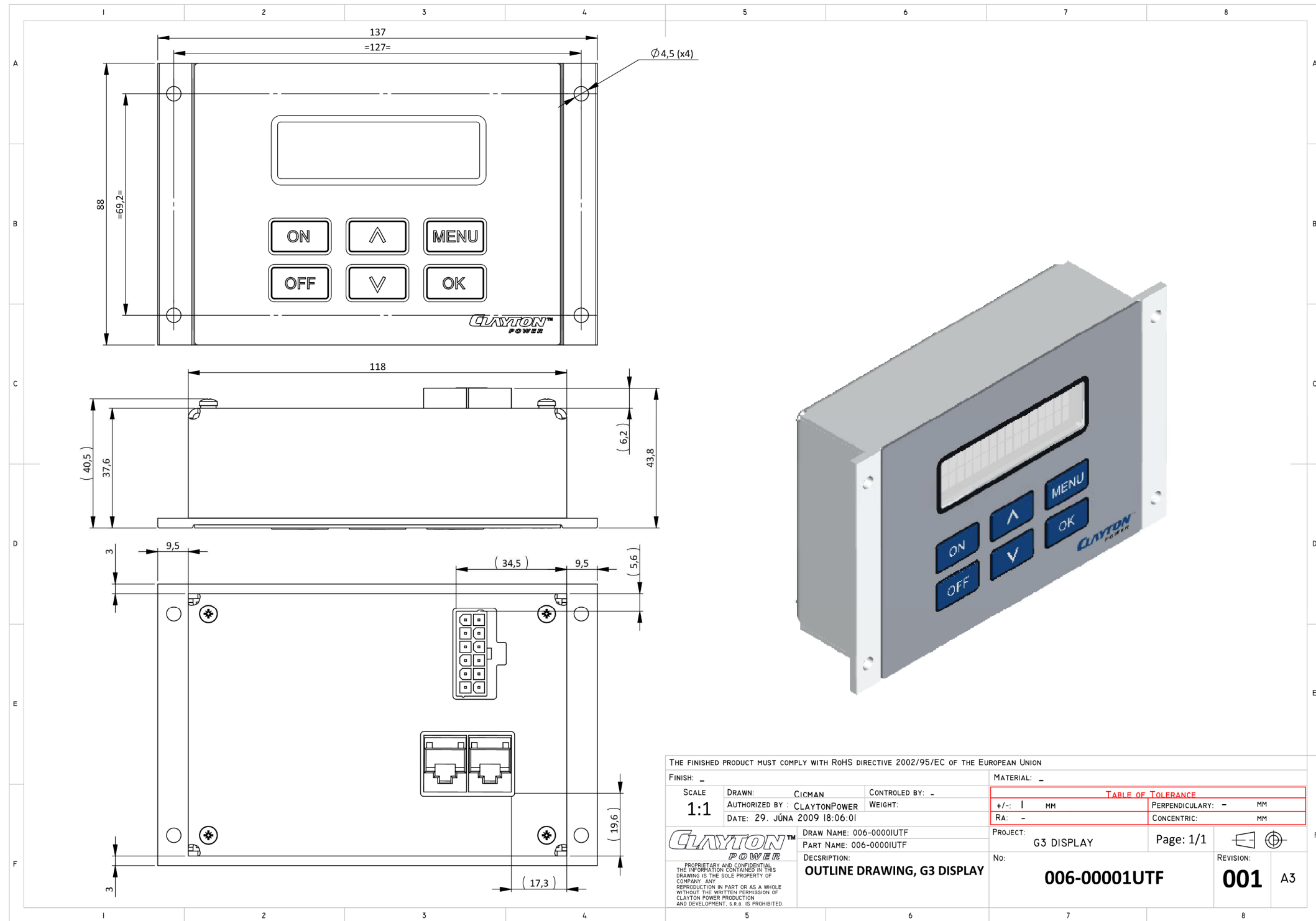

How to Reach Us:

<http://www.claytonpower.com>

CP Development Centre

Clayton Power
Pakhusgården 32
5000 Odense C
Denmark

Phone: +45 46 98 57 60

CP International Sales

Clayton Power
Pakhusgården 32
5000 Odense C
Denmark

Phone: +45 46 98 57 60



Clayton PowerTM and the Clayton Power logo are trademarks of Clayton Power GmbH. All other product or service names are the property of their respective owners. © Clayton Power R&D, s.r.o.. 2009. All rights reserved.

Document Number: 006 – 00001DSF

rev. 003

07/2010