

The LPS II range



CLAYTON
POWER

SAFETY INSTRUCTIONS – UN3480

The Lithium Power Supply (LPS) is classified as Class 9 dangerous goods according to UN3480, a power source with high energy density and hazardous materials in a sealed metal cabinet.

Installation must follow national safety regulations in accordance with the requirements for enclosure, installation, creepage, clearance, marking and segregation requirements for the end-use application. We recommend that installations are performed by authorised professionals. Switch off the system and check for hazardous voltages before changing any connections!
The Lithium Power Supply must only be serviced by trained personnel.

The lowest ingress protection rating for specific LPS parts is IP20. Ensure that the installation of the Lithium Power Supply complies with IP20 requirements.

This is a Class I product. Connect only 230 VAC from a source connected to protective electrical earth, including all extension cords between source and the device.

Observe the following:

When connected to 230 VAC input, voltage is present at 230 VAC output, even when the device is switched off.

Do not open the LPS.

Do not discharge a new LPS until it has been fully charged.

Charge only within the specified limits.

Make sure the LPS is switched off when it is moved and during installing.

Do not mount the LPS upside down or on its side.

Check if the LPS has been damaged during transport.

Do not series- or parallel-connect the 230 VAC output of the LPS.

Do not leave outside exposed to the elements.

Do not use at altitudes above 4500 metres (14765 feet)

Do not cover or block the fan or air intake to ensure that the battery does not overheat.

Do not allow children or animals to come in contact with the device or connected power supplies.

Solar Connection

Solar connection must not exceed the maximum voltage of 50 V.

Danger in case of fire:

Danger of explosion with dust particles.

Decomposition due to fire or heat development emits toxic and corrosive gases.

Combustion gases which strongly irritate the eyes and respiratory organs.

General precautions the driver should observe if these hazards occur:

Switch off the motor.

Place a warning sign on the road to warn others.

Inform others of the dangers and advise them to stay away from the wind direction.

Contact the police and fire brigade immediately and inform them that there are lithium batteries (UN3480) onboard.

Instruction for fire extinguishing:

Extinguish fire with water. If possible, submerge the LPS completely in water.

Extinguishing with water produces fluoride, phosphate, fluoride-oxide and carbon monoxide.

Alternatively, extinguish with a CO2 fire extinguisher.



**NON-SPILL
LI-ION BATTERY**

SAFETY INSTRUCTIONS – UN3480	2
CONTENT	3
1. GETTING STARTED	4
1.1 PRODUCT BOX CONTENTS	4
1.2 PRODUCT DETAILS	4
2. PRODUCT USAGE	6
2.1 230VAC OUTPUT	7
2.2 230VAC CHARGING	8
2.3 12VDC OUTPUT	9
2.4 12VDC/24VDC INPUT	10
2.5 SOLAR CHARGING	11
3. TIPS AND TRICKS	12
3.1 CHARGING THE VEHICLE STARTER BATTERY	12
3.2 LIMIT AC/DC CHARGING POWER	12
3.3 ACTIVATE JUMPSTART	12
3.4 BATTERY MAINTENANCE	13
4. TROUBLESHOOTING	14
4.1 ERROR LIST	14
4.2 NO 230VAC OUTPUT	14
5. SPECIFICATIONS	15
6. BLUETOOTH FUNCTIONALITY	17
6.1 CONNECTING TO THE LPS II	17
6.2 CLAYTON POWER GO MAIN SCREEN	19
7. CERTIFICATIONS AND COMPLIANCE	21
8. SAFETY AND FUSES	21
7.1 INTERNAL MEASURES	21
7.2 EXTERNAL FUSES	22
7.3 CABLES	22
9. STORAGE	23
10. TRANSPORTATION	23
11. DISPOSAL	23
12. WARRANTY	24

**UNIT MUST BE CHARGED
EVERY 6 MONTHS IF NOT
USED**

1. GETTING STARTED

1.1 Product Box Contents

Quantity	Description
1	LPS II
1	AC charging cable (Neutrik – NAC3 FCA)
1	AC output connector (Neutrik – NAC3 FCB)
4	Cap for M8 bolt
4	M8 bolt
2	M4 bolt
4	Rubber foot

1.2 Product Details

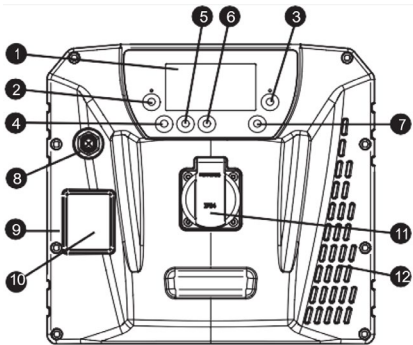
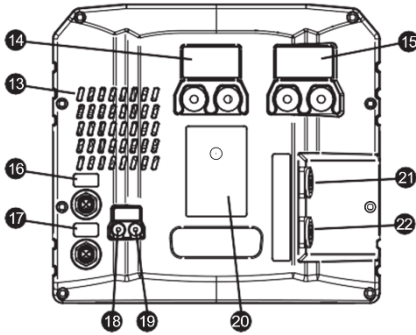
Front View		Rear View	
			
#	Description	#	Description
1	Display	13	Ventilation
2	12 VDC button	14	DC output terminals
3	230 VAC button	15	DC input terminals
4	Navigation button - Down	16	M12 – Data/Remote connector
5	Navigation button - Up	17	M12 – Data/IO connector
6	Navigation button - Ok	18	C1 (D+/Ignition Signal)
7	Navigation button - Return	19	C2 (Solar +) IO terminal
8	M12 – Data/IO connector	20	Type plate
9	Serial number	21	230 VAC output port (NAC3 FCB)
10	RCBO	22	230 VAC input port (NAC3 FCA)
11	230 VAC output port		
12	Ventilation/Fan		

The 12 VDC and the 230 VAC buttons can switch the DC and AC output on and off. If both buttons are pressed and held for 10 seconds, the LPS II will reset without changing any settings.

The four navigation buttons are used to navigate the menus and setting options. If the three arrow buttons are pressed and held for 2 seconds, the LPS II display will reset without changing any settings.

M12 - IO PINOUT		
#	Function	Front View
1	Single Wire (Communication)	
2	I/O Signal	
3	GND	
4	CAN High (Communication)	
5	CAN Low (Communication)	

NOTE: PIN 2 in the M12 connector labeled "REMOTE" is designed to supply power to the LPS Remote. The LPS Remote is not included and can be purchased separately.

The display provides information on the unit operation status and allows for advanced unit configuration. The display features two home screens - a simple view and an advanced view. It is possible to switch between the screens using the UP and DOWN navigation buttons.

DISPLAY – SIMPLE VIEW		
#	Description	View
1	DC input active – Charging from DC source	
2	DC output active – I/O activated	
3	Solar input active – Charging from solar panel	
4	DC output energy saver timer active	
5	AC output energy saver timer active	
6	AC input active – Charging from grid	
7	AC output active – I/O activated	
8	Remaining operation time or time to charge (not shown with Capacity Extension)	
9	Graphical indication of state-of-charge	
10	Numeric indication of state-of-charge	

DISPLAY - ADVANCED VIEW		
#	Description	View
1	DC input functionality	
2	DC output functionality	
3	AC input functionality	
4	AC output functionality	
5	Solar input active – Charging from solar panel	
6	Power bar for indicating utilization of function	
7	Functionality is active and a transfer of energy is in process	
8	Functionality is active but there is no energy transfer	
9	AC output energy saver timer active	
10	Remaining operation time or charge time (not shown with Capacity Extension)	
11	Graphical indication of state-of-charge	
12	Numeric indication of state-of-charge	

NOTE: Interface and product features might vary depending on the model.

2. PRODUCT USAGE

All installations must be carried out by trained and qualified installers.

This document is intended as a general guide for installations and not as a comprehensive, step-by-step manual.

Local rules and regulations must always be followed and take precedence over any instructions provided in this guide.

WARNING: Connecting the device with incorrect voltage or battery polarity will damage the device and is not covered by the warranty.

WARNING: Do not connect the AC outputs in parallel or serial. It will damage the device and is not covered by the warranty.

WARNING: Do not connect the output of a generator or AC mains to the output. It will damage the device and is not covered by the warranty.

It is recommended to perform a full battery cycle prior to the initial use.

To do this charge the LPS II fully, then do a full discharge and then charging it overnight using the 230 VAC input.

When the LPS II is installed in a vehicle and that vehicle is not being used, it is recommended to have the LPS II connected to an AC mains supply.

The LPS II is a compact power supply designed to provide power for a variety of 230 VAC and 12 VDC applications. It comes with built-in:

- LiFePO4 battery.
- 230 VAC Output – For supplying 230 VAC applications.
- 230 VAC Input – For charging from mains.
- 12 VDC Output – High power DC output for supplying 12 VDC applications.
- 12 VDC/24 VDC Input – Bidirectional DC-DC converter for 12 VDC/24 VDC applications like:
 - Vehicle jumpstart
 - Charging from alternator.
- Solar Charging – Integrated MPPT for charging from solar panel.
- CANbus communication and I/O interface for interaction with auxiliary equipment and remote control.

2.1 230VAC Output

The LPS II features two AC output ports, one on the front (CEE 7) and one on the back (NAC3 FCB), which can be used simultaneously. Both ports are protected against overload and short circuits and are equipped with RCDO for safety.

Press the 230V button to activate the AC output function. The green LED will light up to confirm activation. The output will automatically switch off after 1 hour if the power demand is below 20 W (Default setting).

The following diagram illustrates how to connect to an LPS II for this configuration.

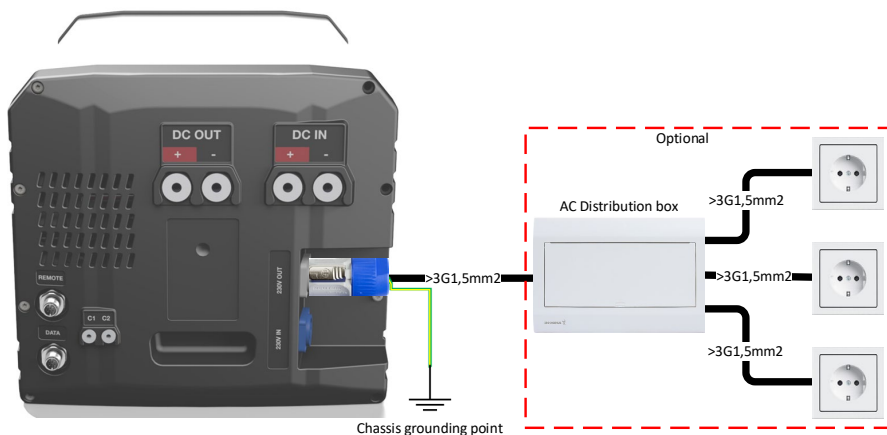

WARNING: A connection from the Neutrik 230 VAC Out connector to Chassis **MUST** be made for protective grounding.

NOTE: The earth pin in the input and output AC connections are internally connected, so chassis connection can be done on either one.

NOTE: If there is no 230 VAC output when the output is turned ON, check RCBO.

2.2 230VAC Charging

To charge the LPS II from a power outlet, use the provided power cord with the NAC3 FCA connector. When connected to mains, the unit will begin charging automatically and redirect the mains to the AC output ports. During charging, the green 230V LED will flash.

If a load is connected to the AC output, this will be prioritized over the internal charging, possibly reducing the power being used for charging.

The following diagram illustrates how to connect to an LPS II for this configuration.



WARNING: 230 VAC will always be present on the AC output ports during AC charging.

WARNING: A connection from the Neutrik 230 VAC Out connector to Chassis **MUST** be made for protective grounding.

NOTE: The earth pin in the input and output AC connections are internally connected, so chasis connection can be done on either one.

2.3 12VDC Output

The LPS II has a 12 VDC port for providing power to DC applications. To activate the 12 VDC output, press the 12V button. A green LED will light up, indicating that the functionality is active.

The following diagram illustrates how to connect to an LPS II for this configuration. Connect the positive DC output terminal of the LPS II to the positive input of the load through an appropriate fuse.

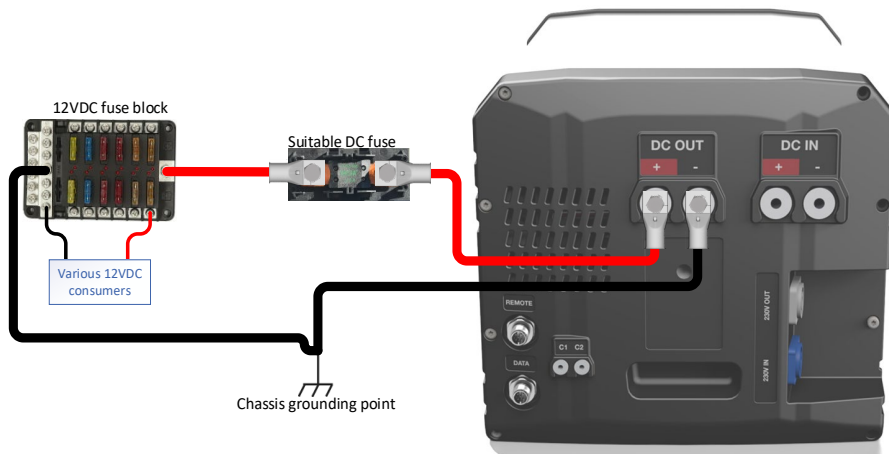

WARNING: Output fuse and cable size, including the grounding cable, should be rated according to the load being used.

WARNING: Using the wrong cable size or a bad cable connection can cause overheating and a short circuit.

WARNING: Place a fuse as close as possible to the LPS to prevent high current short-circuits.

NOTE: The negative DC connection on IN and OUT terminals are internally connected together. Therefore, the chassis earth point can be on either connection.

2.4 12VDC/24VDC Input

The LPS II can be charged using the built-in DC-DC converter when the DC IN port voltage is within the operational range and a wakeup signal is detected on C1.

The following diagram illustrates how to connect to an LPS II for this configuration. Connect the DC positive from the battery through a fuse to the positive DC input terminal on the LPS II.

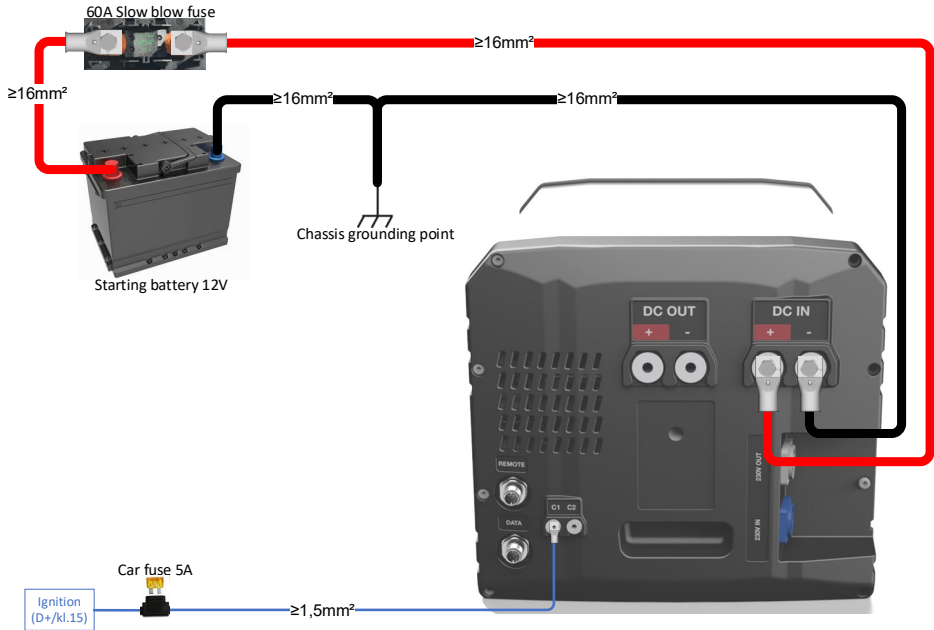

WARNING: Using the wrong cable size or a bad cable connection can cause overheating and a short circuit.

WARNING: Place a fuse as close as possible to the power source to prevent high current short-circuits.

NOTE: The negative DC connection on IN and OUT terminals are internally connected together. Therefore, the chassis earth point can be on either connection.

2.5 Solar Charging

If the solar panels generate enough power ($> 5 \text{ W}$), the LPS II will automatically charge using the integrated MPPT.

The Solar status in the menu will be shown as OFF when the available solar power is not high enough.

For optimal usage, keep the solar panels clean and free of shadows – even a little shadows or small amount of direct can drastically reduce the output of the panels.

The following diagram illustrates how to connect to an LPS II for this configuration.

Connect the solar positive input to the C2 terminal on the LPS.

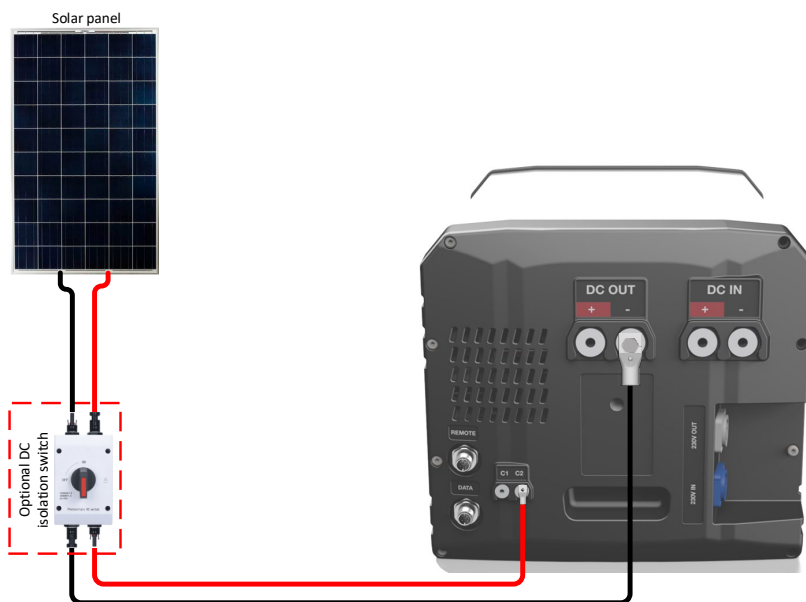

WARNING: Never exceed 50 Voc between DC Input minus and C2 from solar. Exceeding may cause damage to the unit.

WARNING: Cable size should be rated according how much current can be delivered from the solar panel as specified in the datasheet of the solar panel used.

WARNING: Always follow the Solar panel manufacturers safety manual and recommended installation instructions.

WARNING: For two or more parallel installed solar panels, a fuse is recommended for each panel connection if the combined short circuit current for all panels is higher than the maximum reverse current of a single panel.

NOTE: The negative DC connection on the LPS II IN and OUT terminals are internally connected together.

NOTE: Not available in LPS 1500 SE variant.

NOTE: The LPS will charge with a maximum of 400 W from the solar panel. If a higher wattage panel has been fitted, the panel and LPS II will regulate this together and not be damaged.

NOTE: We advise to fit an isolation switch, but this is optional. This allows the power from the panel to be switched off if you need to work on the LPS for any reason.

3. TIPS AND TRICKS

For more details on the LPS II menu structure and functions, please see the LPS II Menu Guide.

This guide explains how to use the menu and what settings can be changed for the different functionalities of the LPS II.

This includes changes to functions such as AC and DC outputs, AC and DC inputs and Solar Charging.

3.1 Charging the vehicle Starter Battery

The LPS II can be set to maintain the charge of the vehicle starter battery.

By turning on this function, the LPS II will charge the vehicle battery when 230 VAC is connected to the AC input, and the SOC is above 98%.

The LPS II will do a normal charge of the starter battery until the charge current gets below the limits set in the menu, then it will lower the charge current to perform maintenance charging.

CHARGE OF STARTER BATTERY	
Menu Path	Description
Main Menu > DC Charging > Charge of Starter Battery	To enable the function, enter the menu and navigate using the up and down arrows. Press "OK" to confirm your selection. The settings will take effect immediately.

3.2 Limit AC/DC charging power

If the power source has limited output, the AC and DC charging can be limited. The below display menu setting will also limit the AC output in the LPS while connected to the mains.

LIMITING AC CHARGING POWER	
Menu Path	Description
Main Menu > 230VAC Charging > Maximum current	To set the maximum allowable current for AC charging, enter the menu and navigate using the up and down arrows. Press "OK" to confirm your selection. This setting will take effect immediately.

NOTE: If 230 V current has been limited, the 230 V output power of the LPS is also limited while connected to the mains.

LIMITING DC CHARGING POWER	
Menu Path	Description
Main Menu > DC Charging > Set current	To set the maximum allowable current for DC charging, enter the menu and navigate using the up and down arrows. Press "OK" to confirm your selection. This setting will take effect immediately.

3.3 Activate Jumpstart

The LPS II has an integrated jumpstart feature that can charge the starter battery if depleted. To use this feature, the LPS must be connected to the starter battery via the DCIN terminal according to section 2.4.

The jumpstart is activated through the display menu or the remote. Once activated, the jumpstart will charge the starter battery for 5 min with 40 A.

ACTIVATE JUMP-START	
Menu Path	Description
Main Menu > DC Charging > Jumpstart	To activate the jumpstart function, enter the menu and use the up and down arrow to select "Active" and press "OK" to confirm.

3.4 Battery maintenance

To ensure optimal battery performance, fully recharge the battery every month (100 %).

To prevent deep discharge of the batteries, the LPS II will go into Sleep Mode when the SOC is below 0%. When in Sleep Mode the LPS II uses a very low amount of power and can last for up to 2 years without being charged.

The Sleep Mode can also be entered manually from the menu.

If the Sleep Mode was entered because of low SOC, it will wake up when the 12V or 230V buttons are pushed (and hold for 1 second), if an AC input is connected, if the C1 signal goes high or if Solar becomes active.

If the Sleep Mode was entered manually from the menu, it will wake up when the 12V or 230V buttons are pushed (and hold for 1 second) or if an AC input is connected.

The wakeup source is disabled if the function had failures when the LPS entered Sleep Mode.

NOTE: Sleep mode is available for units with software version 40 or higher.

NOTE: If the battery has not been fully charged for a long period, maintenance charge can be prolonged up to 3 days.

**UNIT MUST BE CHARGED
EVERY 6 MONTHS IF NOT
USED**

4. TROUBLESHOOTING

4.1 Error list

If the solutions provided below are unable to resolve the error or if the error code is not listed, contact your retailer.

ERROR	DESCRIPTION	SOLUTION
Product Temperature		
4, 5, 56, 57, 123	Unit temperature too low	Let the device warm up or move it to a place with a higher ambient temperature
6, 7, 58, 59	Unit temperature too high	Let the device cool down or move it to a place with a lower ambient temperature
I/O and Communication		
11, 12, 13	M12 connector is overloaded or has short circuited	Disconnect connector and check connector or cable for damage
14	I/O Terminal is overloaded or has short circuited	Disconnect connector and check connector or cable for damage
121	Communication Error	Verify cable connections on M12 connectors
Battery		
51, 52, 53, 60	Battery/Cell voltage low	Recharge the battery
Solar		
70	Solar input voltage too high	Check the installation and max. voltage from solar panel (50V)
DC Input		
90, 92	The DC Input voltage too low	Provide a higher 12 VDC or 24 VDC voltage
91, 124, 125	The DC Input voltage too high	Provide a lower 12 VDC or 24 VDC voltage
93	Unable to charge from vehicle.	Check installation to vehicle battery for loose connections, for low vehicle battery capacity or defect vehicle charger.
DC Output		
96	DC Output charge current too high	Remove or adjust the power source
97	DC Output discharge current too high	The 12VDC Output load is drawing too much current. Remove the load
AC Output		
150, 151, 152, 203	230VAC Output is overloaded	Remove load on the 230 VAC Output
157	SOC cut-off limit	Recharge the unit
AC Input		
206	230VAC mains is too low	Check supply cables or try another outlet socket
207	230VAC mains too high	Mains too high, verify outlet socket voltage

4.2 No 230VAC output

Make sure that the Residual Current Circuit Breaker with Overload protection (RCBO) is switched on (see section 1.2 - #10) and check your AC cables.

5. SPECIFICATIONS

PARAMETER	LPS II 1500 W 1 kWh SE	LPS II 2000 1 kWh	LPS II 2500 1 kWh	LPS II 3000 2 kWh
General				
Model no.	CL2204/CL2214/ CL2224	CL2205/CL2215/ CL2225	CL2102/CL2112/ CL2122	CL2103/CL2113/ CL2123
Cooling	Forced air			
Ambient temperature discharge	-20-40 °C			
Ambient temperature charge	0-40 °C			
Unit self-consumption (Standby mode)	11 mA			
Unit self-consumption (Sleep mode)	1 mA			
IP classification	20			
Protection class	I			
Maximum altitude	4500 m			
Product weight	22.5 kg		23.5 kg	27.5 kg
Product size (H x W x L)	256 x 277 x 409 mm			
Gross weight	25.5 kg		26.5 kg	30.5 kg
Package size (H x W x L)	320 x 372 x 480 mm			
Battery				
Type	Rechargeable Lion battery system			
Chemistry	LiFePO4			
Capacity	100 Ah (1280 Wh)			160 Ah (2048Wh)
Available capacity	80 Ah (1020 Wh)			136 Ah (1740Wh)
Cycles	5000			3500
Self-discharge rate per month	< 3%			
Marking (IEC 61960)	4IFpP51/161/119			4IFpP55/175/154
Marking (IEC 62620)	IFpP/51/161/119/[4S]M/-20+60/90			IFpP/55/175/154/[4S]M/-30+60/90
AC Input				
Voltage	207-253 V			
Frequency	45-65 Hz			
Power	610 W		790 W	
Connector type	NAC3 FCA			
AC Output				
Voltage (+- 10 %)	230 V pure sine wave			
Frequency	50 Hz			
Power - continuous (@ 25 °C)	1500 W	2000 W	2500 W	2800 W
Power - 10 min. (@ 40 °C)	1500 W	2000 W	2500 W	3000 W
Power Peak - 10 s	3000 W	4000 W	5000 W	6000 W
Power – AC in connected	2300 W		3000 W	
Supported peak inrush power	5000 W	7000 W	9000 W	13000 W
Power factor	0.77			

Efficiency (1,000 W)	94 %	
Idle consumption	20 W	
Fault current (rms)	30 mA	
Connector type	NAC3 FCB, Schuko (EU), BS1363 (UK), T23 (CH)	
DC Input		
Voltage	11.5-32 V	
Current	25 A	45 A
Jumpstart	25 A/5 min.	40 A/5 min.
Connector type	Terminal – M8	
DC Output		
Voltage	10-14.4 V	
Discharge current - continuous	180 A	
Discharge current - 1 min.	270 A	350 A
Idle consumption	< 1 W	
Charging current – continuous	90 A	
Connector type	Terminal – M8	
Solar (Input)		
Voltage	N/A	15-50 V
Charging power (max.)	N/A	400 W
Charging current (max.)	N/A	15 A
Short circuit current (Isc)	N/A	30 A
I/O		
Input ports (Analog)	C1, C2, M12	C1, C2, M12 x 3
Input (Voltage – M12)	0-36 V	
Input (Voltage – C1, C2)	0-50 V	
Output ports (Digital)	C2 and M12	C2 and M12 x 3
Output (Voltage)	0 or 12 V	
Output (Current)	400 mA (Overcurrent protected)	
Connector type (M12)	Type A – 5-way	
Connector type (C1/C2)	Terminal – M4	

WARNING: If the temperature gets below -20 °C, the unit will lock and must be returned to Clayton Power for resetting, at the customer's expense.

NOTE: The LPSII will not charge correctly at temperatures below 0 °C, and charging at temperatures below 0 °C can damage the battery cells.

NOTE: The available power is reduced at an increasing rate for temperatures below 0°C.

6. BLUETOOTH FUNCTIONALITY

The LPS II has Bluetooth installed (available from hardware version xx:20 and higher) making it possible to connect to the Clayton Power GO app.

The app is available for Apple and Android phones and can be downloaded by scanning one of the below QR codes.

Android phones



Apple phones



6.1 Connecting to the LPS II

Make sure the Bluetooth is turned on in the LPS II menu and on the phone.

ACTIVATE BLUETOOTH	
Menu Path	Description
Main Menu > General > Bluetooth > Power	To activate the Bluetooth, enter the menu and use the up and down arrow to select "On" and press "OK" to confirm.

Start the Clayton Power GO app on the phone, the app will start up on the Device List screen.

Push the "Connect" button next to the LPS II that is to be connected.

If no devices are listed, push the "Scan" button in the top left corner.

A pin code is needed to connect to the LPS II, this is displayed on the LPS II panel and must be entered when requested during connection.

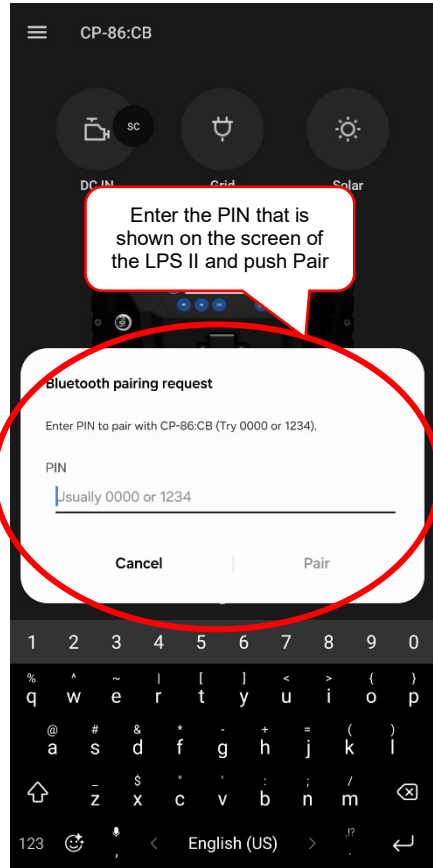
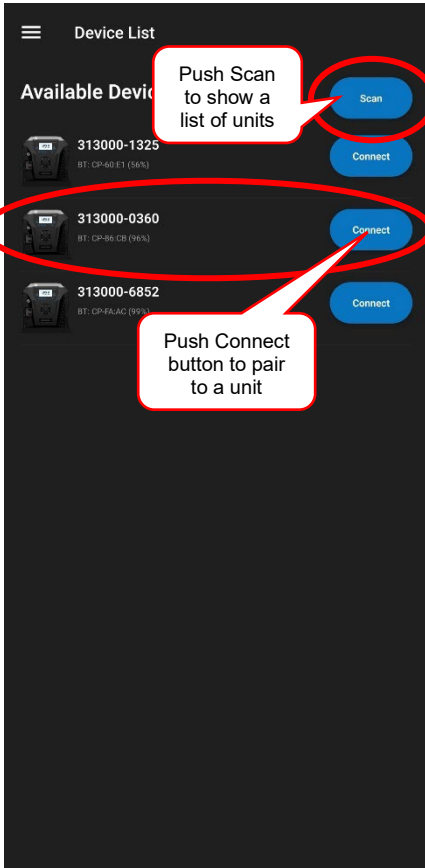

REMOVE CONNECTED PHONES FROM THE LPS II	
Menu Path	Description
Main Menu -> General -> Bluetooth -> Paired Devices	To activate remove devices that have been connected to the LPS II, enter the menu and select the device to be removed, then press "OK" twice to remove it.

6.2 Clayton Power GO main screen

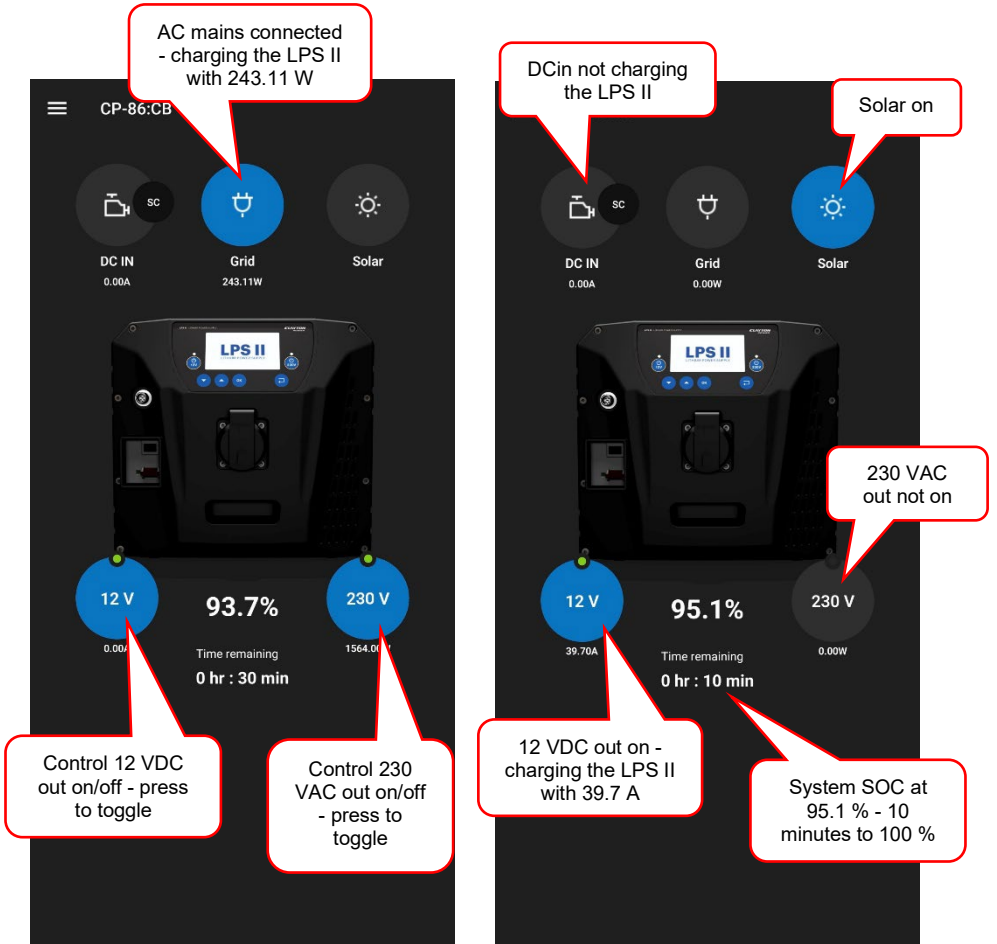

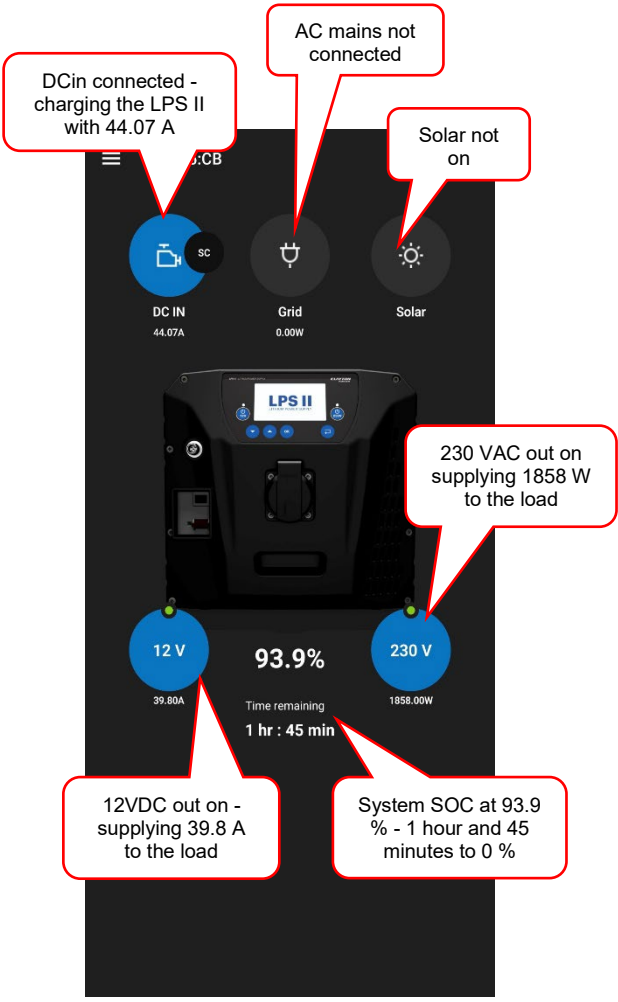

7. CERTIFICATIONS AND COMPLIANCE

Low Voltage Directive 2014/35/EU
EN62368-1, EN62133

RoHS Directive 2011/65/EU
EN 63000

EMC 2014/30/EU
EN61000-6-2, EN61000-6-3

E-Marking
UN-ECE Regulation 10, E5 10R – 06 0488

8. SAFETY AND FUSES

The following measures ensure the safe and secure operation of the electrical system. Not following these measures can result in dangerous situations causing harm to the user and the equipment.

7.1 Internal Measures

- 230 VAC input protected with 16 A fuse.
- 230 VAC output protected by a Residual Current Circuit Breaker with Overload protection (RCBO) 30 mA/13 A.
- DC input protected with 70 A fuse.
- L/N relay hardware protection against hazards.
- PE/N relay hardware protection against hazards.
- Solar panels 16 A fuse.

Fuses cannot be replaced by the user and require service.

ATTENTION: The MPPT/Solar may be permanently damaged if the input voltage exceeds 50 V.

ATTENTION: The device is equipped with a Residual Current Circuit Breaker with Overload protection (RCBO). To ensure its proper operation, it is important to regularly test the RCBO.

Procedure:

- Ensure that 230 VAC is present.
- Locate the button marked 'T' on the RCBO.
- Press the 'T' button.
- Observe the RCBO to ensure that it trips during the test.

If the RCBO becomes disabled, all 230 AC output ports will be disconnected. This is a safety feature to protect the device and those using it. Regular testing of the RCBO ensures that it is functioning properly.

A yearly full RCBO test with a suitable test tool is also recommended but is not a requirement.

ATTENTION: Protective Earth - The device must have protective earth connected.



It is mandatory to install a Protective Earth (PE) connection in accordance with the requirements specified in IEC 62109-1. The PE connection provides a safe route for electrical fault current to flow, reducing the risk of electric shock and fire. Proper installation of the PE connection is essential for ensuring the safety of users and the equipment. Make sure that the PE connection is installed using appropriate materials and methods, in accordance with the relevant national and local regulations.

ATTENTION: Do not connect the CAN Bus to the vehicle's CAN communication system.

7.2 External Fuses

- All fuses must be installed as close to the power source as possible.
 - Measures must be taken to ensure the cable located between the fuse and the power source is laid out in a short-circuit-proof manner.
- Fuses should be clearly marked with their name and size.
- It is important to use fuses rated for DC voltages.
- MEGA fuses (recommended fuse type) should be mounted in holders.

7.3 Cables

- Cables need to be flexible.
 - Cables are rated in different classes related to flexibility.
 - Cables with classification 5 or 6 needs to be used (This cable type is also referred to as HIGH-FLEX).
 - The supplied AC input cable is not for a fixed installation in a leisure vehicle.
- Cables are dimensioned according to the fuse size.
- Always use the designated connection points in the vehicle for chassis and DC connections (if available/indicated).
- Always route cables the shortest way possible.
- Cables should always be secured along the routing to ensure that it does not move unintentionally.
- Cable must be kept away from moving parts.
- When passing through bulkheads or other surfaces the cable needs to be guarded against chamfering.
 - This can be done by grinding the hole to eliminate sharp edges, using a rubber grommet within the hole and using conduit or tubing to shield the cable.
- Cable terminals should be used for the right cable cross section as they are made for.
- It is important to choose cable terminals for the right cable classification.
 - This means that classification 5 cables need a classification 5 terminal.
- When connecting the cable remember to use the right torque.
 - M8 bolts must be torqued to 12 Nm
 - M4 bolts must be torqued to 2.5 Nm
- When connecting the cable remember to use both spring and straight washer.

9. STORAGE

The LPS II can be stored at temperatures between -20 °C and 50 °C. For long term storage (> 1 month), the LPS II should be fully charged and stored at temperatures between 0 °C and 35 °C. Do not store the LPS II upside down.

WARNING: Storage in a place with temperatures higher or lower than above, may damage the battery inside the LPSII. This is not covered by warranty

**UNIT MUST BE CHARGED
EVERY 6 MONTHS IF NOT
USED**

10. TRANSPORTATION

Lithium batteries are classified as Class 9 hazardous materials (UN3480) and must always be transported in compliance with all applicable local, national, and international regulations. Proper packaging is required during transportation, and packaging instructions (PI965) must be respected. The batteries should not be turned upside down during transportation.

11. DISPOSAL

To ensure proper disposal and reduce potential hazards, discharge the battery completely before placing it in a designated battery recycling bin. Improper disposal, such as throwing it in regular rubbish bins, is strictly prohibited as the product contains batteries with potentially harmful chemicals. Adhere to local laws and regulations for battery recycling and disposal.

12. WARRANTY

IMPORTANT AND WARNING:

DO NOT USE OR ATTEMPT TO USE THIS PRODUCT UNTIL YOU HAVE READ THE USER MANUAL IN ITS ENTIRETY. IMPROPER INSTALLATION OR USE OF THIS DEVICE MAY BE DANGEROUS AND MAY CAUSE DAMAGE TO OTHER ELECTRICAL EQUIPMENT AND WILL VOID THE WARRANTY.

Warranty. The company guarantees that products and associated services are free of significant defects in design, material and execution for 24 months after delivery.

Exceptions. The company's warranty does not include defects caused by: (i) ordinary wear and tear, (ii) storage, installation, use or maintenance against the company's instructions or ordinary practice, (iii) repair or change carried out by others than the company, and (iv) other conditions for which the company has no responsibility.

Examination. Within a reasonable period of time after receiving a complaint from the client about defects and examining the claim, the company will inform the client about whether or not the defects are covered by the warranty. After the request, the client must ship defective parts to the company. The client covers the expenses and risks of the parts during transport to the company. The company covers the expenses and risks for return of parts during transport, only if the defects are covered by the warranty.

Register a complaint. If the client discovers defects within the period of warranty, which the client wishes to invoke, it must be communicated immediately in writing. If defects, which the client discovers or should have discovered, are not immediately communicated to the company in writing, it cannot be effectuated at a later time. The client must provide the company the requested information about the registered defects.

Instructions for Obtaining Warranty Service for Clayton Power Devices

To obtain warranty service, contact the store where you have bought the product and provide the following:

- Sales receipt
- Device model number
- Device serial number
- Brief description of the application and problem, including any error codes displayed on the device.
- Obtain an authorisation number from the Clayton Power dealer before shipping the device. Carefully pack the device and ship it (freight paid) to the Clayton Power dealer. Note that the device contains lithium batteries and must be shipped as dangerous goods according to UN3480 lithium-ion batteries' regulations.

Sales: sales@claytonpower.com

Service: service@claytonpower.com

Phone: +45 4698 5760

Address: Pakhusgaarden 42-48
DK-5000 Odense C



CLAYTON
POWER