



System installation guide

Installation guide for E-GEN

[Resumé](#)

This guide explains what is important when doing an installation with E-GEN.

Jacob Wrøbell

jkw@claytonpower.com

Table of contents

Table of contents	2
1) Scope	3
2) Installation diagram	3
3) Connections	5
3.1) E-GEN module connections	5
3.2) Battery module connections	7
4) Maximum current rating of E-GEN connections	7
5) Installing the modules in the vehicle	8
6) Connecting the Battery modules	9
6.1) Connecting power	9
6.2) Connecting CAN communication	9
7) Connecting the DC Input	9
8) Connecting the DC Output	9
9) Connecting the Solar	9
10) Connecting the ignition/D+/KL15 signal	10
11) Connecting the IOT modem and CAN Termination	10
12) Connecting 230 VAC Input	10
13) Connecting 230 VAC Output	10
14) Connecting 400V AC Output	10
A1) General recommendation on fuse selection and placement	11
A1.1) DC input	11
A1.2) DC output	11
A1.3) AC input (one phase only)	12
A1.4) AC output (per phase)	12
A1.5) Solar connections (per connection pair)	12
A1.6) Ignition signal (C1)	12
A1.7) Fuse size versus cable cross section	13
A2) General requirements for connections	13
A3) General recommendations for cables and routing	14
A4) General recommendations for Solar panel mounting	15

Description: System installation guide	Created by: JKW Date: 21-05-2025	Reviewed by: Approved by: Date:	Rev: 3.0 By: JKW Date: 4-MAY-2026
--	-------------------------------------	---------------------------------------	---

1) Scope

This guide describes how to do an installation with an E-GEN in a vehicle.

This guide only describes the installation itself, and only the connections on the following Clayton Power products are included:

- E-GEN
- Battery modules
- Solar panels
- Display
- Remote
- IOT modem
- Fuses (only MEGA fuses)

For information on how to install other products, refer to the guide/manual of that product.

This document should be used together with the **E-GEN installation functional test guide**.

2) Installation diagram

Figure 2.1 shows a standard E-GEN installation and is shown for reference.

The actual installation might be different, but the major connections should still be the same.

For information on other installation setups please contact Clayton Power support.

Description: System installation guide	Created by: JKW Date: 21-05-2025	Reviewed by: Approved by: Date:	Rev: 3.0 By: JKW Date: 4-MAY-2026
--	-------------------------------------	---------------------------------------	---

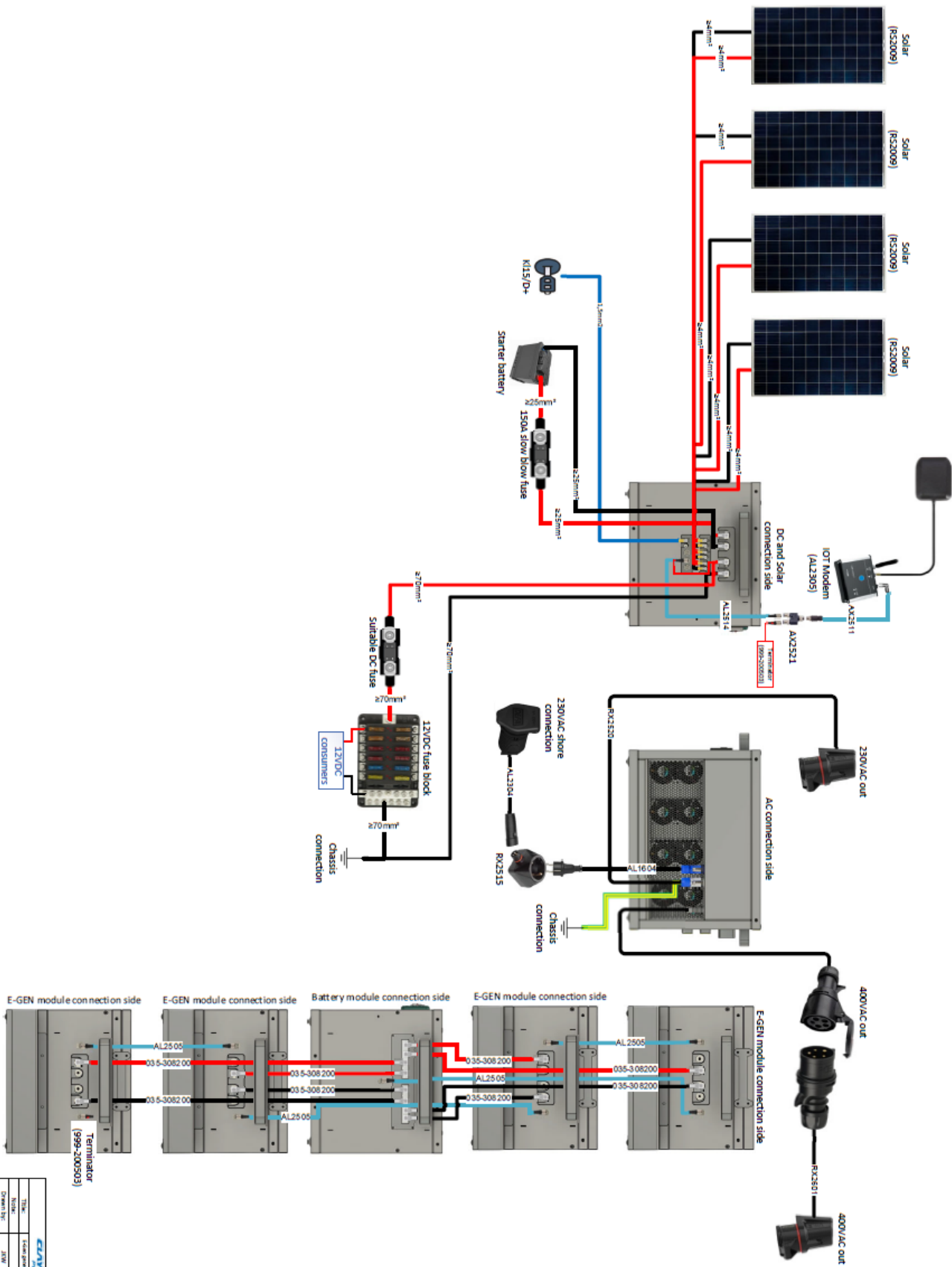

Figure 2.1 - Standard installation

CLAYTON POWER
Model: [999-200903]
Drawn by: JKW

Description: System installation guide	Created by: JKW Date: 21-05-2025	Reviewed by: Approved by: Date:	Rev: 3.0 By: JKW Date: 4-MAY-2026
--	-------------------------------------	---------------------------------------	---

3) Connections

The following sections show the different connections on the E-GEN and Battery modules.

For connections on the other Clayton Power products please refer to the appropriate manuals.

3.1) E-GEN module connections

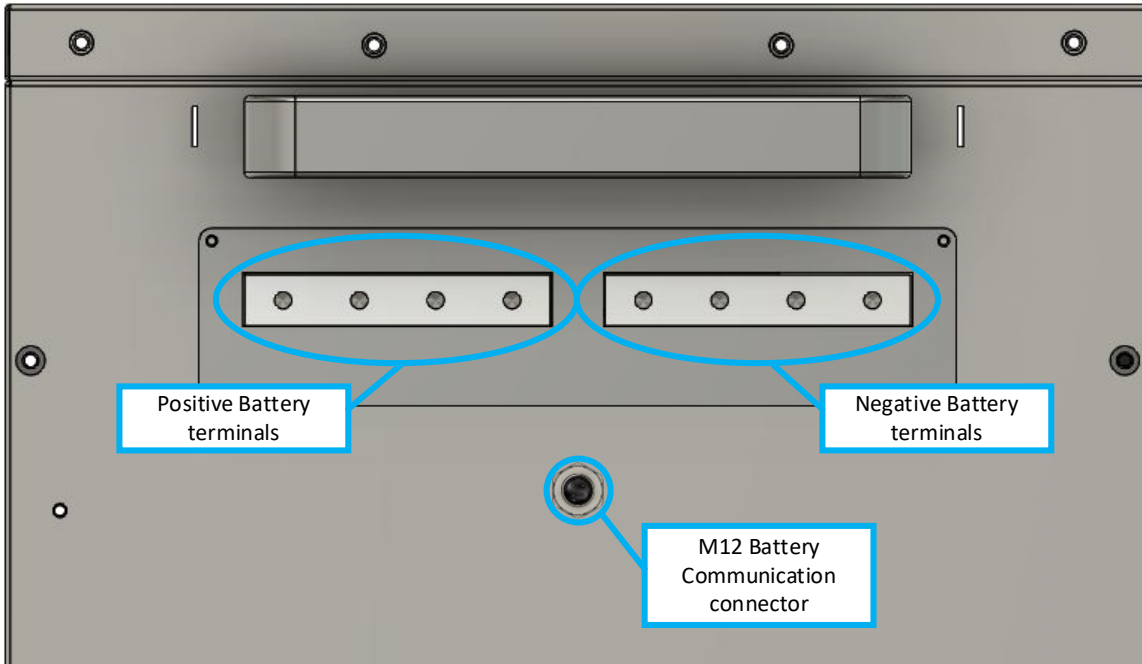

Figure 3.1 - Battery module connection side

Description: System installation guide	Created by: JKW Date: 21-05-2025	Reviewed by: Approved by: Date:	Rev: 3.0 By: JKW Date: 4-MAY-2026
--	-------------------------------------	---------------------------------------	---

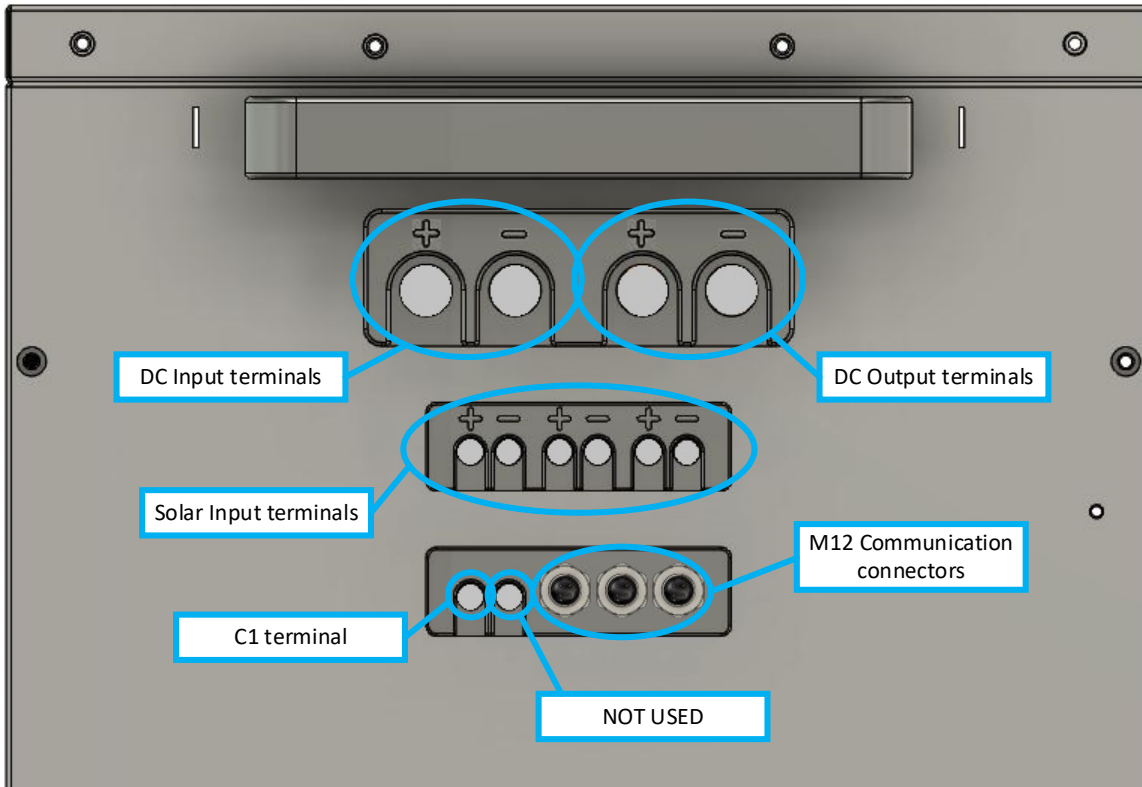

Figure 3.2 - DC and Solar connection side

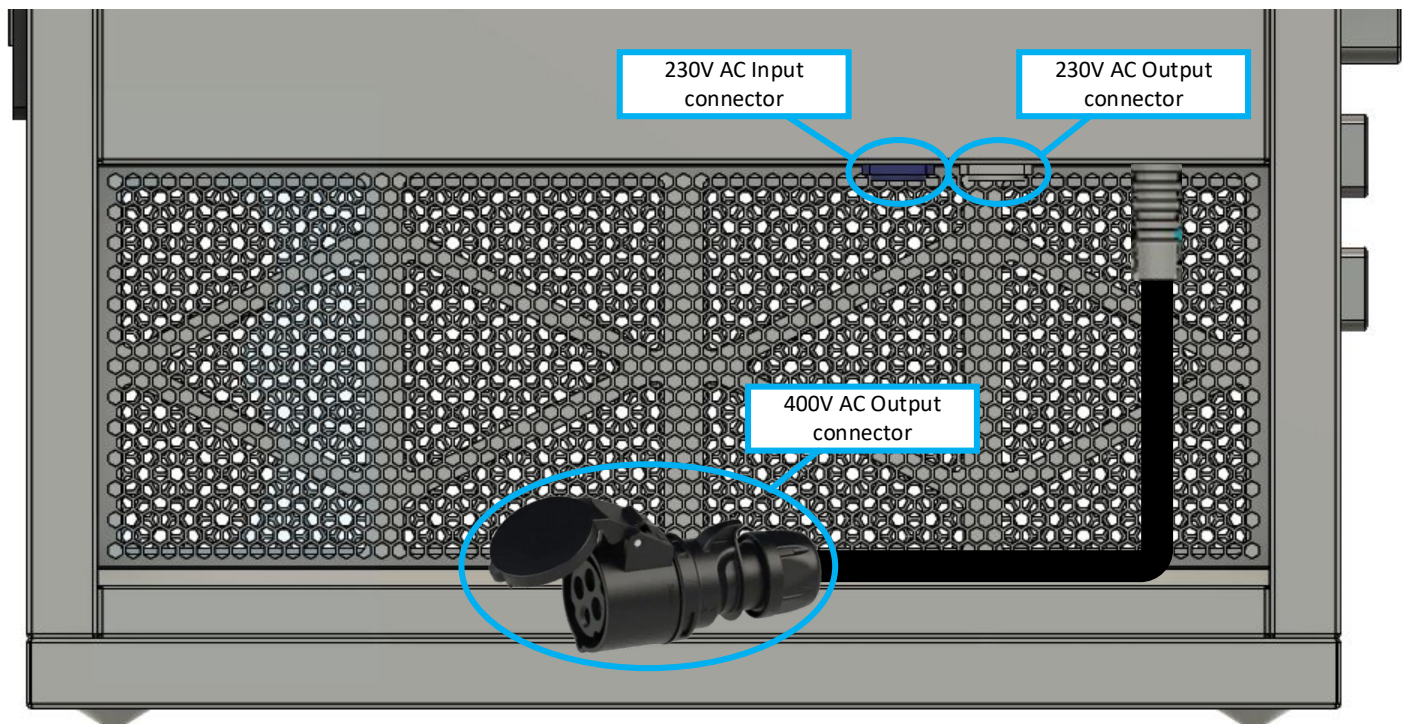

Figure 3.3 - AC connection side

Description: System installation guide	Created by: JKW Date: 21-05-2025	Reviewed by: Approved by: Date:	Rev: 3.0 By: JKW Date: 4-MAY-2026
--	-------------------------------------	---------------------------------------	---

3.2) Battery module connections

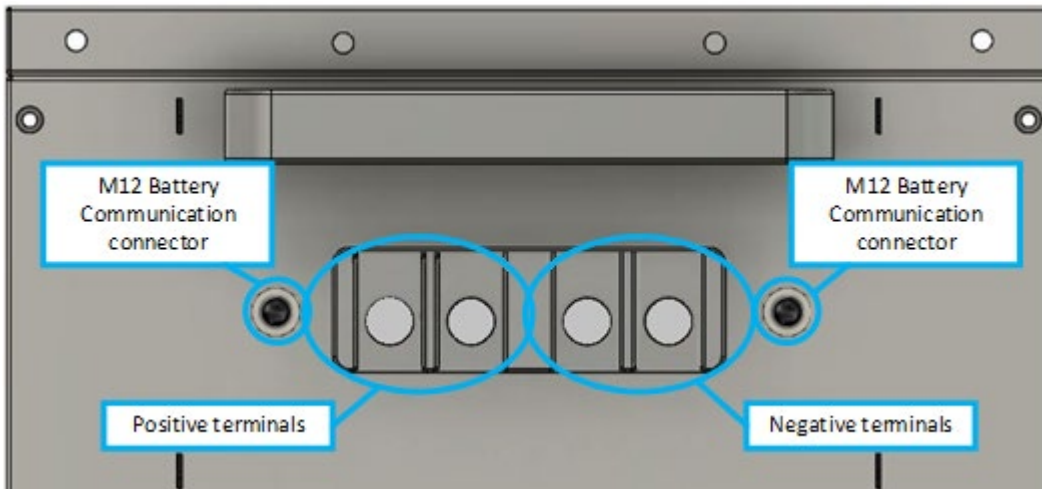

Figure 3.4 - E-GEN module connection side

4) Maximum current rating of E-GEN connections

As seen on the installation diagram it is normally the DC connections that are protected with external fuses, whereas the AC connections are protected internally by a RCBO.

However in some cases it might be needed to install external fuses for the AC connections also.

The maximum current that the different E-GEN connections can handle is listed in section A1).

These are used for selection fuse and cable cross section.

The fuse and cable size of the AC and DC output connections depends on the load.

If no information about the load is available, the fuse and cable size should be dimensioned according to the maximum available current from the E-GEN.

The fuse and cable size of the DC input depends on the available current from the vehicle battery.

If no information about the current is available, the fuse and cable size should be dimensioned according to the maximum current draw from the E-GEN.

Description: System installation guide	Created by: JKW Date: 21-05-2025	Reviewed by: Approved by: Date:	Rev: 3.0 By: JKW Date: 4-MAY-2026
--	-------------------------------------	---------------------------------------	---

5) Installing the modules in the vehicle

The E-GEN is designed for tower installation, where the modules are stacked on top of each other in the order shown in Figure 5.1.

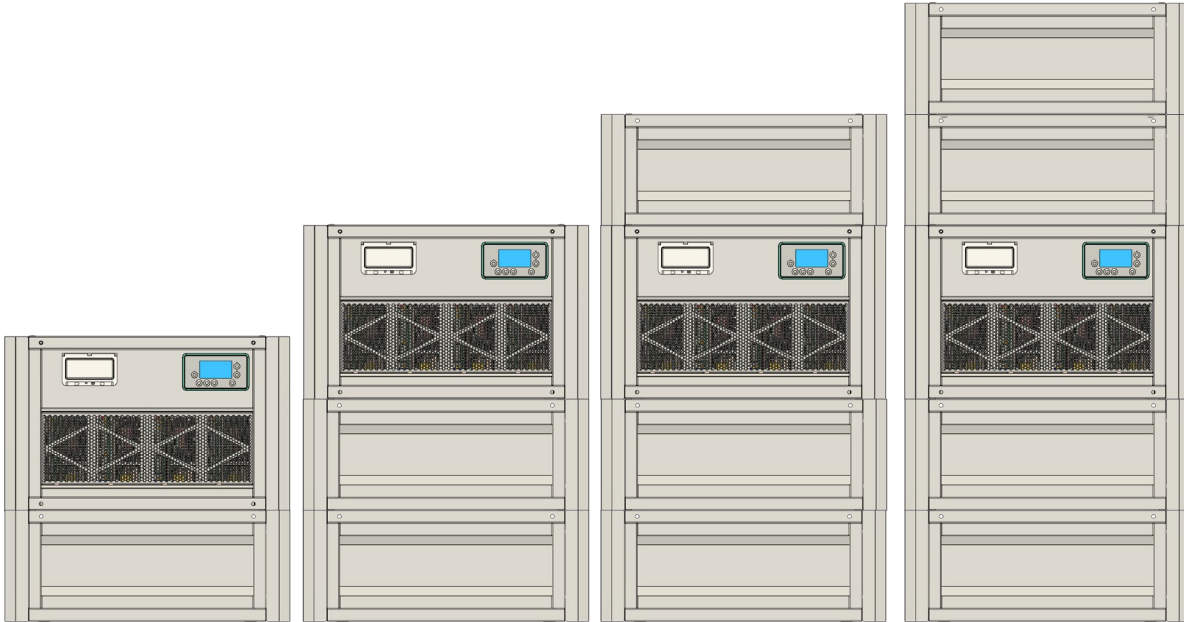

Figure 5.1 - How to stack the modules correctly

Each module is secured to the next with two dog bone shaped brackets (delivered with the Battery modules) as shown on Figure 5.2.

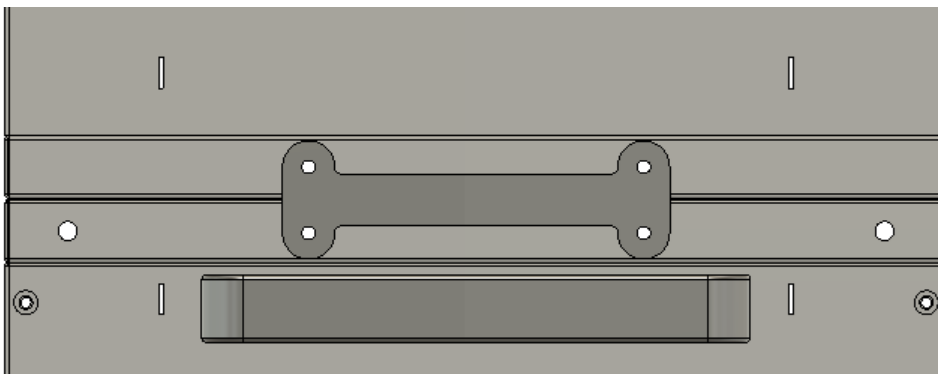

Figure 5.2 - Module securing bracket

The RCD should be easily accessible, and the same is recommended for the display unless a remote is installed.

The total assembly must be secured to the vehicle in a way that fits with the vehicle internal layout. It must be secured to withstand vehicle movement when driving.

The product is NOT designed or tested to be used in a vehicle unsecured.

Description: System installation guide	Created by: JKW Date: 21-05-2025	Reviewed by: Approved by: Date:	Rev: 3.0 By: JKW Date: 4-MAY-2026
--	-------------------------------------	---------------------------------------	---

6) Connecting the Battery modules

6.1) Connecting power

Each Battery module must be connected to the E-GEN module with cables delivered from Clayton Power.

Depending on the installation size, different cables are used:

Cable number	Number of cables			
	6 kWh	12 kWh	18 kWh	24 kWh
035-308200	2	4	6	8

Do not alter the cable length.

The connections are done between the positive and negative terminals on the Battery modules to the positive and negative Battery terminals on the E-GEN module shown on Figure 3.1 and Figure 3.4 in section 3).

The short cables are used for the Battery modules closest to the E-GEN module and the long cables are used for the Battery modules furthest away from the E-GEN module.

6.2) Connecting CAN communication

A CAN Communication cable (part number AL2505 delivered with the Battery modules) must be connected from the M12 Battery Communication connectors on each Battery module to the next, and from one Battery module to the E-GEN module.

Do not connect the communication cable to the M12 Battery Communication connector on the E-GEN module yet, as this might cause the system to wake up unintentionally.

Connect a CAN Termination (included in the E-GEN Connector kit - part number AL2515) on the unused M12 Communication connector of one of the Battery modules.

7) Connecting the DC Input

The DC Input must be connected to the DC Input terminals shown on the E-GEN module on Figure 3.2 from the vehicle battery/alternator through a suitable fuse (see section 4) for details on fuse and cable size).

8) Connecting the DC Output

The DC Output must be connected to the DC Output terminals on the E-GEN module shown on Figure 3.2 to the load through a suitable fuse (see section 4) for details on fuse and cable size).

The DC Output negative terminal must be connected to chassis for ground reference.

9) Connecting the Solar

The Solar panels should be connected to the Solar Input terminals on the E-GEN module shown on Figure 3.2.

If more than three panels are connected, they should be evenly distributed across the three sets of terminals (i.e. 1/1/2 or 2/2/3 but not 1/1/3 or 1/2/3), and they should be connected in parallel.

Description: System installation guide	Created by: JKW Date: 21-05-2025	Reviewed by: Approved by: Date:	Rev: 3.0 By: JKW Date: 4-MAY-2026
--	-------------------------------------	---------------------------------------	---

If more than two panels are connected to a set of terminals it is recommended to add a fuse to each connection, if the combined short circuit current, for all panels connected to the same terminal, is higher than the maximum reverse current of a single panel.

10) Connecting the ignition/D+/KL15 signal

The ignition signal from the vehicle (also called D+ signal or KL15 signal) should be connected to the C1 terminal on the E-GEN module shown on Figure 3.2 through a suitable fuse (see section 4) for details on fuse and wire size).

11) Connecting the IOT modem and CAN Termination

The IOT modem should be connected through a CAN Split and a CAN communication cable (part numbers AX2511, AX2521 and AL2514 delivered with the E-GEN order) to either one of the M12 Communication connectors on the E-GEN module shown on Figure 3.2.

The extra wire on the AL2514 should be connected to the positive DC output terminal.

A CAN Termination (included in the E-GEN Connector kit - part number AL2515) should also be connected to the CAN Split cable.

12) Connecting 230 VAC Input

Included in the E-GEN Connector kit there is an AC input cable with a Neutrik connector and a Schuko connector (part number AL1604), also included is a DEFA cable kit (part number AL2304) and a DEFA Schuko connection point (RX2515).

These parts are used for connecting the 230 VAC Input to the 230 VAC Input connector shown on Figure 3.3.

13) Connecting 230 VAC Output

The E-GEN Connector kit also includes an AC output cable with a Neutrik and a CEE connector (part number RX2520), this is used for connecting the 230 VAC output to the 230 VAC Output connector shown on Figure 3.3.

The earth wire in the AC cable must be connected to chassis for the RCD to work correctly.

14) Connecting 400V AC Output

The three phase 400 VAC output connector is a standard CEE female connector on 2m long flexible cable as shown on Figure 3.3, this should be connected to the 400 VAC output extension/conversion cable (part number RX2601) from the E-GEN Connector kit.

Description: System installation guide	Created by: JKW Date: 21-05-2025	Reviewed by: Approved by: Date:	Rev: 3.0 By: JKW Date: 4-MAY-2026
--	-------------------------------------	---------------------------------------	---

Appendix

A1) General recommendation on fuse selection and placement

All fuses must be installed as close to the power source as possible.

Measures must be taken to ensure the cable located between the fuse and the power source is laid out in a short-circuit-proof manner.

This entails either encasing the cable in flexible tubing or employing other protective measures to prevent short circuits in that area.

All fuses should be accessible without the need of tools.

Fuses should be mounted in fuse holders.

Fuses should be clearly marked with their name and size.

The following specifications must be considered when selecting a fuse:

- Fuse type: It is important to use fuses rated for DC voltages on DC lines and fuses rated for AC voltages on AC lines.
- Current rating: The current at which the fuse will open.
- Interrupting rating: The current that a fuse can interrupt without being destroyed or causing an electric arc of unacceptable duration.
- Time-delay (Slow-blow): A fuse in which the time it takes for the overcurrent heat to build up in the fuse and melt the fuse element is long, making the fuse able to handle temporary overload currents.
- Fast-acting: A fuse that opens on overload and short circuits very quickly. It is not designed to withstand temporary overload currents associated with some electrical loads.

A1.1) DC input

Parameter	Maximum rating
Voltage	32 VDC
Charging current	100 A

Table 1 - DC input ratings

A1.2) DC output

Parameter	Maximum rating
Voltage	14.4 Vdc
Discharge current - continuous	180 A
Discharge current - 1 min	270 A

Table 2 - DC output ratings

Description: System installation guide	Created by: JKW Date: 21-05-2025	Reviewed by: Approved by: Date:	Rev: 3.0 By: JKW Date: 4-MAY-2026
--	-------------------------------------	---------------------------------------	---

A1.3) AC input (one phase only)

Parameter	Maximum rating
Voltage	253 VAC
Charging current	7.5 A
Current – AC out connected	13 A

Table 3 - AC input ratings

A1.4) AC output (per phase)

Parameter	Maximum rating
Voltage	230 VAC
Current - continuous	13 A
Current - 10 min	16 A
Current - AC in connected (only one phase)	13 A

Table 4 - AC output ratings

A1.5) Solar connections (per connection pair)

Parameter	Maximum rating
Voltage	50 VDC
Charging current	15 A
Short circuit current (Isc)	30 A

Table 5 - Solar connection ratings

The following must be considered when verifying the Solar fuse rating:

- No fuse is needed for an installation with a single or two solar panel.
- For three or more parallel installed solar panels a fuse is recommended, if the combined short circuit current for all panels is higher than the maximum reverse current (or fuse current) of a single panel.
 - Each panel should have a fuse, and it should be placed as close to the panel as possible.
- Since a solar panel cannot be turned off, it is recommended to place a DC isolation switch at the DC+ output of the panel.
 - If a DC isolation switch is used the rating of the switch should be verified as well.
- Always follow the Solar panel manufacturers safety manual and recommended installation instructions.

A1.6) Ignition signal (C1)

Parameter	Maximum rating
Voltage	50 VDC
Activation current (max)	0.5 A

Table 6 - Ignition signal rating

Description: System installation guide	Created by: JKW Date: 21-05-2025	Reviewed by: Approved by: Date:	Rev: 3.0 By: JKW Date: 4-MAY-2026
--	-------------------------------------	---------------------------------------	---

A1.7) Fuse size versus cable cross section

Table 7 shows the maximum fuse to be used at a given cable cross section.

The values are based on a hard short circuit, meaning that the current will be several times higher than the fuse rating.

For a hard short circuit the length of the cable is not relevant, only the cross-section size.

Cable cross section values shown are for reference only, all cables should be dimensioned according to local rules and regulations.

This is especially, but not exclusively, relevant for the DC output cables

Cable cross section [mm ²]	Maximum fuse rating [A]
1.5	7.5
2.5	12
4	20
6	30
10	50
16	80
25	110
35	140
50	170
70	210
95	260
120	300

Table 7 - Cable cross section versus fuse rating

A2) General requirements for connections

The following must be considered when doing connection:

1. That polarity is correct.
 - a. This is easily done if DC wiring is done with red (for positive DC voltage) and black (for negative DC voltage) cables.
2. That all plugs are correctly mounted, tightened and undamaged.
 - a. AC plugs, Neutrik plugs, PV solar connectors and M12 connectors.
3. That spring washer are used on all electrical assembly to ensure better connection, especially when it is exposed to vibration.
4. That all bolts are tightened with the torques in Table 8.
 - a. Torques in Table 8 are for 8.8 class bolts that are used on Clayton Power products.
5. The bolts are marked when correctly tightened.
6. Always use the designated connection points in the vehicle for chassis and DC connections (if available/indicated).
7. Push connector (spring loaded terminals) is the preferred solution for thin cables (<6mm²).
 - a. The reason for this is that vibration does not affect the installation the same way as with screw connection where the screw can come loose over time.

Description: System installation guide	Created by: JKW Date: 21-05-2025	Reviewed by: Approved by: Date:	Rev: 3.0 By: JKW Date: 4-MAY-2026
--	-------------------------------------	---------------------------------------	---

- b. Push connectors can handle both cables that are “raw” and also cables with ferrules.
- 8. In some installation is it not possible to avoid screw connections.
 - a. When using a screw connector, the cable should always be mounted with ferrule.

Thread	Required tightening torque [Nm]
M3	1
M4	2.5
M5	5
M6	8
M8	12
Fuse holder terminal	5

Table 8 - Torque versus thread size

A3) General recommendations for cables and routing

1. Cables should be flexible
 - a. Classification 5 or 6 is recommended (This cable type is also referred to as HIGH-FLEX).
2. Always route cables the shortest way possible.
3. Cables should always be secured along the routing to ensure that it does not move unintentionally.
 - a. It is recommended to fix the cable for every 300mm.
4. Cable must be kept away from moving components and airbags.
5. When passing through bulkheads or other surfaces the cable needs to be guarded against chamfering.
 - a. This can be done by grinding the hole to eliminate sharp edges, using a rubber grommet within the hole or using conduit or tubing to shield the cable.
6. Cable terminals should be used for the cable cross section that they are made for.
7. It is important to choose cable terminals for the right cable classification.
 - a. This means that classification 5 cables need a classification 5 terminal.
8. Cable terminals should be crimped and tested according to Table 9.

Cable size [mm ²]	Minimum pull force [N]	Minimum pull force [kg]
6	120	12
10	200	20
16	320	33
25	500	51
35	700	71
50	1000	102
70	1400	143
95	1900	193
120	2400	244

Table 9 - Pull force for testing cable terminal crimping

Description: System installation guide	Created by: JKW Date: 21-05-2025	Reviewed by: Approved by: Date:	Rev: 3.0 By: JKW Date: 4-MAY-2026
--	-------------------------------------	---------------------------------------	---

A4) General recommendations for Solar panel mounting

1. Solar panels are best mounted flat on the roof.
 - a. Angled mounted solar panels might give more power but will also require the vehicle to be facing the right way, for the sun's rays to reach the solar panels.
 - b. Angled mounted solar panels will also greatly reduce the aerodynamics of the vehicle and increase the height.
2. Make sure that no other roof mounted parts are shadowing the solar panels from the sun, as this can reduce the power production significantly or even stop the panel from working.
3. Always follow the Solar panel manufacturers safety manual and recommended installation instructions.

Description: System installation guide	Created by: JKW Date: 21-05-2025	Reviewed by: Approved by: Date:	Rev: 3.0 By: JKW Date: 4-MAY-2026
--	-------------------------------------	---------------------------------------	---