

# 600W Bidirectional DC-DC Converter range



**CLAYTON**  
POWER

<b>CONTENT</b> .....	<b>2</b>
<b>1. GETTING STARTED</b> .....	<b>3</b>
1.1 PRODUCT BOX CONTENTS .....	3
1.2 PRODUCT DETAILS.....	3
<b>2. PRODUCT USAGE</b> .....	<b>5</b>
2.1 CHARGE ALGORITHM.....	6
2.2 ANCILLARY TO STARTER BATTERY INSTALLATION .....	7
2.3 BATTERY TO OPEN OUTPUT INSTALLATION .....	8
2.4 SUPER CHARGER INSTALLATION (NOT POSSIBLE WITH CD1805) .....	9
2.5 JUMP START.....	10
<b>3. SPECIFICATIONS</b> .....	<b>11</b>
3.1 DC INPUT OPERATION.....	11
<b>4. CERTIFICATIONS AND COMPLIANCE</b> .....	<b>12</b>
<b>5. SAFETY</b> .....	<b>12</b>
5.1 FUSES .....	12
5.2 CABLES .....	12
<b>6. STORAGE</b> .....	<b>12</b>
<b>7. WARRANTY</b> .....	<b>13</b>

# 1. GETTING STARTED

## 1.1 Product Box Contents

Quantity	Description
1	600W Bidirectional DC-DC Converter
1	M12 connector
3	M6 nut
3	16 mm2 cable lug
4	16 mm self-tapping mounting screws
1	Manual

## 1.2 Product Details

Connection overview	#	Description
	1	Power indicator
	2	Power direction OUT
	3	Power direction IN
	4	Jump start button
	5	Jumpstart indicator
	6	Communication indicator
	7	OUT voltage level indicator
	8	IN voltage level indicator
	9	M12 - Data/IO connector
	10	DC OUT terminal
	11	GND/Chassis terminal
	12	DC IN terminal

M12 - IO PINOUT		
#	Function	Front view
1	Single Wire (Communication)	
2	I/O Signal / D+ Ignition Signal	
3	GND	
4	CAN High (Communication)	
5	CAN Low (Communication)	

LED behaviour			
LED	Behaviour	Indication	Description
Power	Green	Solid	Active - wakeup signal active
	Green	1 Flash	Standby - wakeup signal active
Charge IN or OUT	Green	Solid	Charging has finished - battery full
	Green	Flash 1 Hz	Constant voltage - (Lead: > 80 %) - (Lithium: > 95 %)
	Green	Flash 4 Hz	Constant current - (Lead: < 80 %) - (Lithium: < 95 %)
Charge IN & OUT	Red	1 Flash	Short circuit - restart to recover
	Red	2 Flash	Temperature too high - recovers automatically
	Red	3 Flash	All other failures
Jumpstart	Green	Solid	Jumpstart in final minute - Start the vehicle.
	Green	Flash 4 Hz	Jumpstart in progress - do not start the vehicle yet
	Red	Flash	Jumpstart not able to run.
Data	Green	Solid	CAN active - device controlled
	Green	Flash 1 Hz	CAN active - unknown device
IN/OUT 12V	Green	Solid	12 V functionality active
IN/OUT 24V	Green	Solid	24 V functionality active
IN/OUT 12V & 24V	Green	Solid	Automatic selection is in process
IN/OUT 12V / 24V	Red	Flashing	Voltage is out of range.

## 2. PRODUCT USAGE

**All installations must be carried out by trained and qualified installers.**

**This document is intended as a general guide for installations and not as a comprehensive, step-by-step manual.**

**Local rules and regulations must always be followed and take precedence over any instructions provided in this guide.**

**WARNING:** Connecting the device with incorrect voltage or battery polarity will damage the device and is not covered by the warranty.

The 600W Bidirectional DC-DC Converter is a compact converter designed to provide charging for a variety of 12 VDC and 24 VDC applications. It comes with built-in:

- 12 V/24 V Input – Bidirectional DC-DC converter for 12 V/24 V applications like:
  - Vehicle jumpstart
  - Charging from alternator.
  - Capacity extension.
  - Super Charge.
- CAN bus communication and I/O interface for interaction with auxiliary equipment and remote control.

## 2.1 Charge Algorithm

Standalone charging is always controlled through the M12 I/O connector, with the following functionality.

Pin 1 state (only valid for CD1804)	Pin 2 state	Function
High	High	<b>- DO NOT USED -</b>
High	Low	Power transfer from OUT power terminal to IN.
Low	High	Power transfer from IN power terminal to OUT.
Low	Low	No power transfer.

The Charge algorithm is a 5-stage charge cycle with three levels.

Level 1 charges the battery with high current allowing active loads.

Level 2 performs absorption charging at lower current avoiding gas voltage.

Level 2 state is time limited avoiding infinite charging due to active loads.

Float (Level 3) is when the battery is fully charged, a float charge will keep the battery full even if loads are active. Charging will restart if loads absorb more than allowed during float.

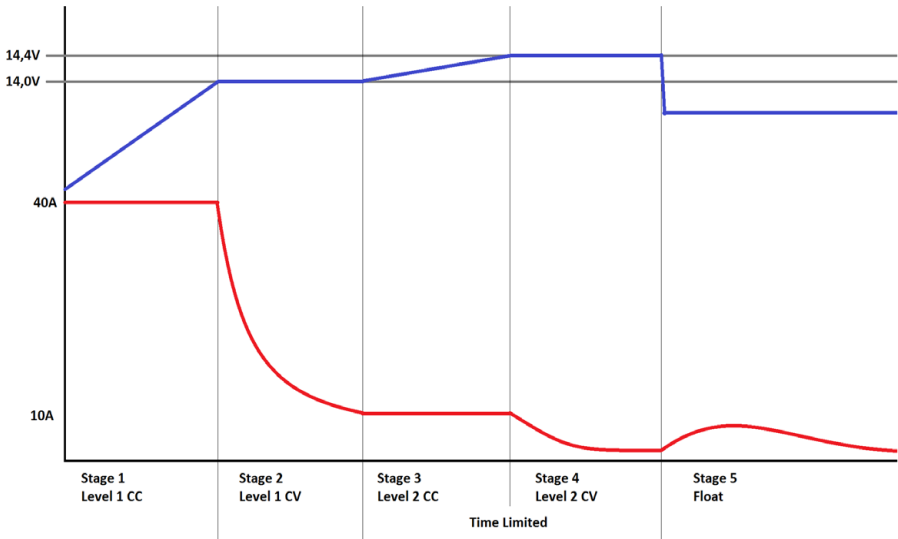

Charge algorithm			
Stage	Description	Value (12 V)	Value (24 V)
Stage 1	Level 1 Constant current	40 A	20 A
Stage 2	Level 2 Constant voltage	14,0 V	28,0 V
Stage 3	Level 1 Constant current <sup>1</sup>	10 A	10 A
Stage 4	Level 2 Constant voltage <sup>1</sup>	14,4 V	28,8 V
Stage 5	Float charge <sup>2</sup>	13,5 V	27,0 V

1 - Level 2 stage is time limited to 8 h and hereafter the battery is considered full.

2 - If the current overpass 10 A during float charge charging is restarted at stage 1.

## 2.2 Ancillary to Starter Battery Installation

Configuration of the converter when used with different battery types and voltages, is only necessary in case of an old or worn-out battery that has a voltage significantly different from its nominal voltage, as the converter is then not able to automatically detect the battery type and voltage.

The following diagram illustrates how to connect the DC-DC converter between an ancillary battery and the vehicle battery/accumulator, so that it will charge when the vehicle battery when the vehicle engine is on. Connect the vehicle battery/accumulator to the OUT terminal of the DC-DC converter, and the ancillary battery to the IN terminal and the ignition signal (D+/KL15) to pin 2 of the M12 on the DC-DC converter.

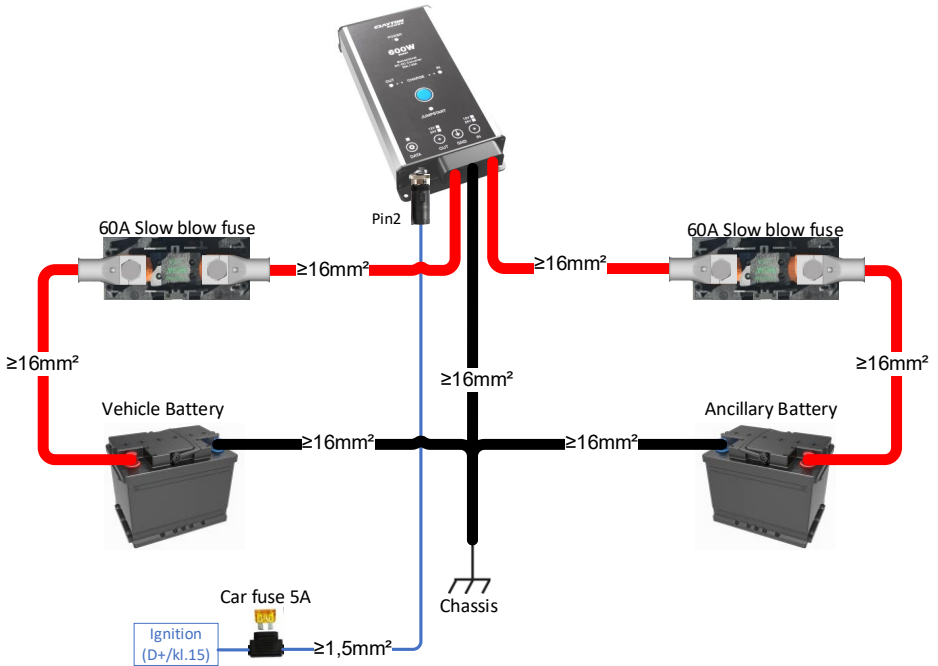

**WARNING:** Using the wrong cable size or a bad cable connection can cause overheating and a short circuit.

**WARNING:** Place fuses as close as possible to the power source to prevent high current short-circuits.

## 2.3 Battery to Open Output Installation

When using the converter in an Open Output setup it must be configured for correct voltage and output mode as open output and not charging a battery.

See configuration manual for a description of how to do this.

The following settings must be changed from default:

Setting Block	Setting	Value
Basic Settings	Output Mode	9 (Open Output CCCV 12V)
CCCV Output Levels	12V Range Output Voltage	12,0 V

The following diagram illustrates how to connect the DC-DC converter between a vehicle battery and the load, so that it will deliver power to the load when the vehicle battery when the vehicle engine is on.

Connect the battery to the IN terminal of the DC-DC converter, and the load to the OUT terminal and the ignition signal (D+/KL15) to pin 2 of the M12 on the DC-DC converter.

If the setup is not using the vehicle battery and the load should be permanently power, the pin 2 connection from the M12 should be to a permanent 12 Vdc signal, this could for instance be the IN terminal.

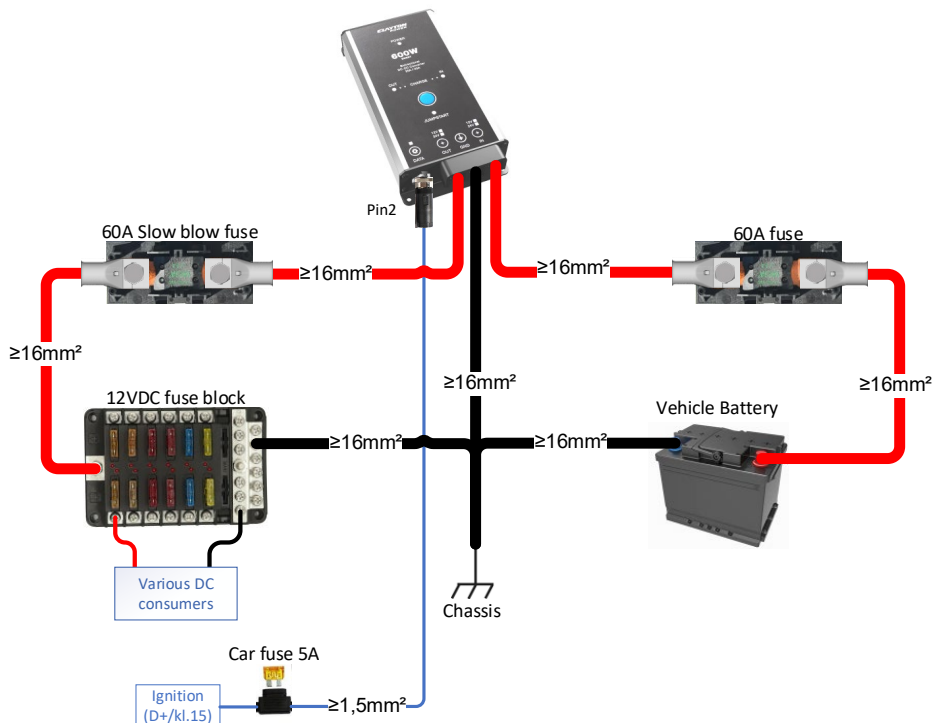

**WARNING:** Using the wrong cable size or a bad cable connection can cause overheating and a short circuit.

**WARNING:** Place fuses as close as possible to the power source to prevent high current short-circuits.



## 2.4 Super Charger installation (not possible with CD1805)

When used with an LPS II the DC-DC Converter can provide faster charging from the vehicle battery to the LPS II.

SETTINGS FOR SUPER CHARGE	
Menu Path	Description
Main Menu > General > I/O voltage > Activate 12VDC on C1	For the Super Charge function to work, enter the menu and use the up and down arrow to select "On" and press "OK" to confirm. This will make the DC output turn on when C1 is high.

The following diagram illustrates how to connect the DC-DC converter between the LPS II and the vehicle battery, so that it will charge when the vehicle battery when the vehicle engine is on.

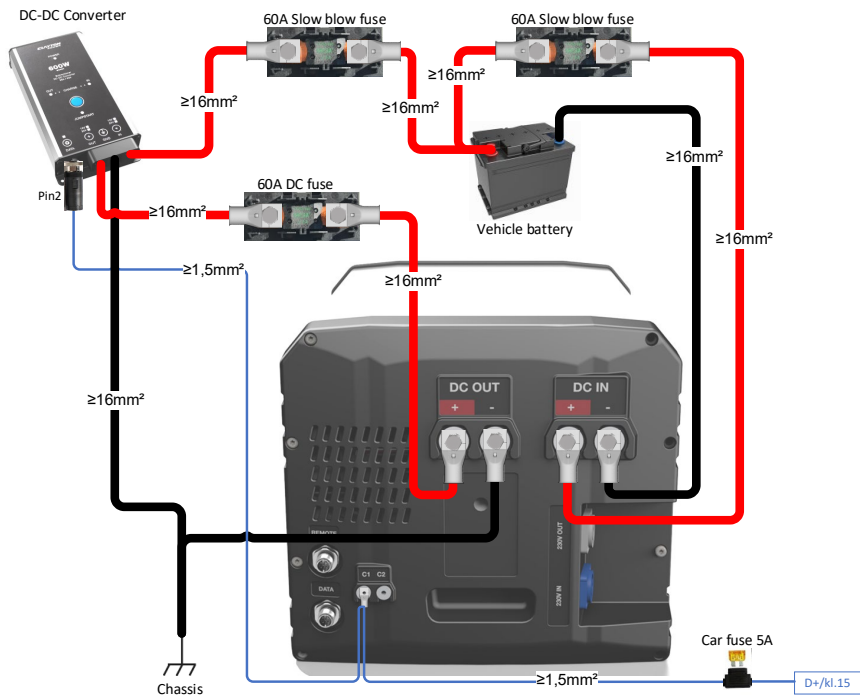

**WARNING:** Using the wrong cable size or a bad cable connection can cause overheating and a short circuit.

**WARNING:** Place fuses as close as possible to the power source to prevent high current short-circuits.

**WARNING:** If a DC load is connected to the LPS II it will turn on when the Capacity extension function is running (since the LPS II DC out is turned on), so an isolation switch between the LPS II and the load might be needed.

## 2.5 Jump Start

The DC-DC Converter can provide reverse charge current into the starter battery giving the option of start aid.

The DC-DC Converter will reverse charge into the starter battery for 5 min. then the user should be able to start the vehicle.

To activate the Jumpstart function:

- Turn ignition on.
- Push 3 sec on the blue Jumpstart button on the DC-DC Converter.

This will activate reverse charging for 5 min.

Reverse charging can be terminated at any time by pushing the blue Jumpstart button again.

### 3. SPECIFICATIONS

PARAMETER	VALUE			
	<b>General</b>			
SKU no.	CD1802	CD1803	CD1804	CD1805
Cooling	Passive			
Operating temperature range	-20-50 °C			
IP classification	20			
Product weight	620 g			
Product size (L x W x H)	222 mm x 110.5 x 40 mm			
Pre-configured for output voltage	12 V			24 V
Pre-configured for battery type	Lead Acid	Lithium battery		
Pre-configured for install type	Charge	Charge	Capacity Extension	Charge
	<b>Electrical</b>			
Supply Voltage	10.9-32 V			
Input Current @ 12 V	0-45 A			
Input Current @ 24 V	0-20 A			
Output Voltage	14.4-28.8 V			
Output Current @ 12 V	0-40 A			
Output Current @ 24 V	0-20 A			
Output Control	5 stage charge			
Power consumption (Idle)	< 1.6 W			
Power consumption (Sleep)	< 1 mW			
Connector type	Terminal – M6			
	<b>I/O</b>			
Input ports (Analog)	M12			
Input (Voltage – M12)	0-36 V			
Output ports (Digital)	M12			
Output (Voltage)	0 or 12 V			
Output (Current)	400 mA (overcurrent protected)			
Wakeup Input (Deactivate)	< 3.0 V			
Wakeup Input (Activate - Delayed 15 sec)	> 4.0 V			
Connector type (M12)	Type A – 5-way			

#### 3.1 DC Input Operation

Parameter	Value (12 V)	Value (24 V)
Undervoltage (1 sec)	11.5 V <sup>1</sup>	23.0 V <sup>1</sup>
Undervoltage (30 sec)	12.0 V <sup>1</sup>	24.0 V <sup>1</sup>
Undervoltage Recover	12.2 V	25.6 V
Overvoltage (1 sec)	17.0 V	34.0 V
Overvoltage (30 sec)	16.0 V	32.0 V
Overvoltage Recover	15.0 V	32.0 V

1 - Voltages are compensated by current coming into the DC-DC Converter with a predefined impedance of 15 mΩ. (ex: 40 A \*15 mΩ = 600 mV Compensation).

## 4. CERTIFICATIONS AND COMPLIANCE

**Low Voltage Directive 2014/35/EU**  
EN62368-1

**RoHS Directive 2011/65/EU**  
EN 63000

**EMC 2014/30/EU**  
EN61000-6-2, EN61000-6-3

**E-Marking**  
UN-ECE Regulation 10, E13 10R-05 14880

## 5. SAFETY

**The following measures ensure the safe and secure operation of the electrical system. Not following these measures can result in dangerous situations causing harm to the user and the equipment.**

### 5.1 Fuses

- All fuses must be installed as close to the power sources as possible.
  - Measures must be taken to ensure the cable located between the fuse and the power source is laid out in a short-circuit-proof manner.
- Fuses should be clearly marked with their name and size.
- It is important to use fuses rated for DC voltages.
- MEGA fuses (recommended fuse type) should be mounted in holders.

### 5.2 Cables

- Cables need to be flexible.
  - Cables are rated in different classes related to flexibility.
  - Cables with classification 5 or 6 need to be used (This cable type is also referred to as HIGH-FLEX)
- Cables are dimensioned according to the fuse size.
- Always use the designated connection points in the vehicle for chassis and DC connections (if available/indicated).
- Always route cables the shortest way possible.
- Cables should always be secured along the routing to ensure that it does not move unintentionally.
- Cable must be kept away from moving parts.
- When passing through bulkheads or other surfaces the cable needs to be guarded against chamfering.
  - This can be done by grinding the hole to eliminate sharp edges, using a rubber grommet within the hole and using conduit or tubing to shield the cable.
- Cable terminals should be used for the right cable cross section as they are made for.
- It is important to choose cable terminals for the right cable classification.
  - This means that classification 5 cables need a classification 5 terminal.
- When connecting the cable remember to use the right torque.
  - 8 Nm torque for M6 terminals.
- When connecting the cable remember to use both spring and straight washer.

## 6. STORAGE

The converter can be stored at temperatures between -20 °C and 50 °C.

## 7. WARRANTY

### **IMPORTANT AND WARNING:**

**DO NOT USE OR ATTEMPT TO USE THIS PRODUCT UNTIL YOU HAVE READ THE USER MANUAL IN ITS ENTIRETY. IMPROPER INSTALLATION OR USE OF THIS DEVICE MAY BE DANGEROUS AND MAY CAUSE DAMAGE TO OTHER ELECTRICAL EQUIPMENT AND WILL VOID THE WARRANTY.**

**Warranty.** The company guarantees that products and associated services are free of significant defects in design, material and execution for 24 months after delivery.

**Exceptions.** The company's warranty does not include defects caused by: (i) ordinary wear and tear, (ii) storage, installation, use or maintenance against the company's instructions or ordinary practice, (iii) repair or change carried out by others than the company, and (iv) other conditions for which the company has no responsibility.

**Examination.** Within a reasonable period of time after receiving a complaint from the client about defects and examining the claim, the company will inform the client about whether or not the defects are covered by the warranty. After the request, the client must ship defect parts to the company.

The client covers the expenses and risks of the parts during transport to the company. The company covers the expenses and risks for return of parts during transport, only if the defects are covered by the warranty.

**Register a complaint.** If the client discovers defects within the period of warranty, which the client wishes to invoke, it must be communicated immediately in writing. If defects, which the client discovers or should have been discovered, are not immediately communicated to the company in writing, it cannot be effectuated at a later time. The client must provide the company the requested information about the registered defects.

### **Instructions for Obtaining Warranty Service for Clayton Power Devices**

To obtain warranty service, contact the store where you have bought the product and provide the following:

- Sales receipt
- Device model number
- Device serial number
- Brief description of the application and problem, including any error codes displayed on the device.
- Obtain an authorisation number from the Clayton Power dealer before shipping the device. Carefully pack the device and ship it (freight paid) to the Clayton Power dealer.

**Sales:** sales@claytonpower.com

**Service:** service@claytonpower.com

**Phone:** +45 4698 5760

**Address:** Pakhusgaarden 42-48  
DK-5000 Odense C



**CLAYTON  
POWER**