

# The Li-G4 range



**CLAYTON**  
POWER

## SAFETY INSTRUCTIONS – UN3480

The Li-G4 is classified as Class 9 dangerous goods according to UN3480, a power source with high energy density and hazardous materials in a sealed metal cabinet.

Installation must follow national safety regulations in accordance with the requirements for enclosure, installation, creepage, clearance, marking and segregation requirements for the end-use application. We recommend that installations are performed by authorised professionals. Switch off the system and check for hazardous voltages before changing any connections!  
The Lithium Power Supply must only be serviced by trained personnel.

The lowest ingress protection rating for Li-G4 is IP54. Ensure that the installation of the Lithium Power Supply complies with IP54 requirements.

### Observe the following:

- Do not open the Li-G4.
- Do not discharge a new Li-G4 until it has been fully charged.
- Charge only within the specified limits.
- Make sure the Li-G4 is switched off when it is moved and during installing.
- Do not mount the Li-G4 upside down or on its side.
- Check if the Li-G4 has been damaged during transport.
- Do not leave outside exposed to the elements.
- Do not use at altitudes above 2000 metres (6562 feet)
- Do not allow children or animals to come in contact with the device or connected power supplies.

### Danger in case of fire:

- Danger of explosion with dust particles.
- Decomposition due to fire or heat development emits toxic and corrosive gases.
- Combustion gases which strongly irritate the eyes and respiratory organs.

### General precautions the driver should observe if these hazards occur:

- Switch off the motor.
- Place a warning sign on the road to warn others.
- Inform others of the dangers and advise them to stay away from the wind direction.
- Contact the police and fire brigade immediately and inform them that there are lithium batteries (UN3480) onboard.

### Instruction for fire extinguishing:

- Extinguish fire with water. If possible, submerge the Li-G4 completely in water.
- Extinguishing with water produces fluoride, phosphate, fluoride-oxide and carbon monoxide.
- Alternatively, extinguish with a CO<sub>2</sub> fire extinguisher.



**NON-SPILL  
LI-ION BATTERY**

**SAFETY INSTRUCTIONS – UN3480 ..... 2**

**CONTENT ..... 3**

**1. GETTING STARTED ..... 4**

1.1 PRODUCT BOX CONTENTS ..... 4

1.2 PRODUCT DETAILS ..... 4

**2. PRODUCT USAGE ..... 6**

2.1 INTERFACE ..... 6

2.2 SYSTEM CONFIGURATION – STANDALONE (CHARGE FROM ACCUMULATOR) ..... 7

2.3 SYSTEM CONFIGURATION – CAPACITY EXTENSION FOR LPS II ..... 8

2.4 SYSTEM CONFIGURATION – BATTERY W. COMBI. .... 10

**3. TROUBLESHOOTING ..... 11**

3.1 ERROR LIST ..... 11

**4. SPECIFICATIONS ..... 12**

**5. CHARGE PROFILE AND SETTINGS ..... 13**

**6. SAFETY ..... 14**

6.1 INTERNAL MEASURES ..... 14

6.2 EXTERNAL FUSES ..... 14

6.3 CABLES ..... 14

**7. CERTIFICATIONS AND COMPLIANCE ..... 15**

**8. BATTERY MAINTENANCE ..... 15**

**9. STORAGE ..... 15**

**10. TRANSPORTATION ..... 15**

**11. DISPOSAL ..... 16**

**12. WARRANTY ..... 16**

**UNIT MUST BE CHARGED  
EVERY 6 MONTHS IF NOT  
USED**

# 1. GETTING STARTED

## 1.1 Product Box Contents

Quantity	Description
1	Li-G4 Battery
2	M12 connectors
2	Cap for M8 bolt
2	M8 bolt
1	M4 bolt
4	Rubber foot
4	Single Edge Mounting Bracket (With screws)
2	Dual Edge Mounting Bracket

## 1.2 Product Details

Front View		Rear View	
#	Description	#	Description
1	DC+ terminal	8	Type plate
2	DC- terminal	9	Pressure valve
3	Power button		
4	SOC indication		
5	Wake-up (M4 terminal)		
6	M12 – Data / I/O connector ( <b>Isolated</b> )		
7	M12 – Data / I/O connector ( <b>Isolated</b> )		

**NOTE:** The wake-up (M4 terminal) provides remote control for the battery's output. The battery turns on at voltages above 4 V and turns off when the voltage falls below 3 V.

M12 pinout		Front View
#	Function	
1	Single Wire (communication)	
2	I/O Signal	
3	Signal GND	
4	CAN High	
5	CAN Low	

**NOTE:** All ports of the M12 connector are isolated and do not have any voltage potential reference to terminal voltage or terminal ground.

## 2. PRODUCT USAGE

**All installations must be carried out by trained and qualified installers.**

**This document is intended as a general guide for installations and not as a comprehensive, step-by-step manual.**

**Local rules and regulations must always be followed and take precedence over any instructions provided in this guide.**

**WARNING:** Connecting the device with incorrect voltage or battery polarity will damage the device and is not covered by the warranty.

Li-G4 is a module-based lithium iron phosphate battery (LiFePO<sub>4</sub>/LFP) which is a safe and reliable chemistry for energy storage. The product is available in 2 variants with capacities of 100Ah and 280 Ah to satisfy demanding applications. The nominal voltage of a Li-G4 module is 12.8 V. The Li-G4 series has an integrated battery management system to protect the cells from deep discharge, overcharge and overheating. The product features:

- Safe battery technology – LiFePO<sub>4</sub>.
- Integrated Battery Management system.
- Integrated power switch.
- Designed for heavy duty environments and requirements.
- Metal frame and flame-retardant enclosure.
- CAN bus communication (compliant with SAE J1939) which is used for:
  - Control
  - Synchronization (System configuration)
  - Data logging
  - Firmware update

Ensuring the safe installation of lithium batteries is mandatory to prevent any potential hazards. The battery comes equipped with built-in protection mechanisms, including short-circuit and overcurrent protection, as well as an internal fuse that is not user replaceable.

**ATTENTION:** It is mandatory to add an additional fuse as close as possible to the positive terminal, with a rating that aligns with your power requirements.

### 2.1 Interface

The battery is equipped with a button and LEDs for operation and indication. The battery is considered off when no LED is illuminated in the State of Charge (SoC) indication bar. When the device is turned on, the SoC indication bar will display the remaining battery capacity in 20 % increments. Following table explains normal operation and warnings that are indicated by the SoC indication bar:

LED	Behaviour	Indication
Green LEDs	Solid	Battery is active and 5 LEDs show State of Charge.
	Flashing	Battery is charging and 5 LED's show State of Charge.
Red LEDs	Solid	Battery is active but too cold for charging, 5 LED's show State of Charge.
1 Red LED	Solid	Battery is nearly empty (<10 % SOC)
	Flashing	Battery is empty and disconnected

The SoC indication bar also serves to display error codes. An error will trigger a red flashing SoC indication bar, with the number of flashes corresponding to the specific failure. You can find a list of error codes on chapter 3.1. Errors can be cleared by turning the battery off and on, depending on the type of error.

## 2.2 System configuration – Standalone (Charge from accumulator)

The Li-G4 can be used as a standalone power source for auxiliary appliances. The following diagram illustrates how to connect the battery to an accumulator for charging during a drive.

To control the charging process, a Clayton Power DC-DC converter is used. This converter prevents the system from draining the accumulator and only charges it when the voltage is within specified limits and a wake-up signal (Pin 2 – M12 connector) is present.

Connect the positive DC from the Li-G4 to the OUT terminal of the DC-DC converter, and the positive DC from the vehicle battery/accumulator to the IN terminal.

Connect appliances to the terminals of the battery and use an appropriate cable thickness with a fuse that supports the appliances current.

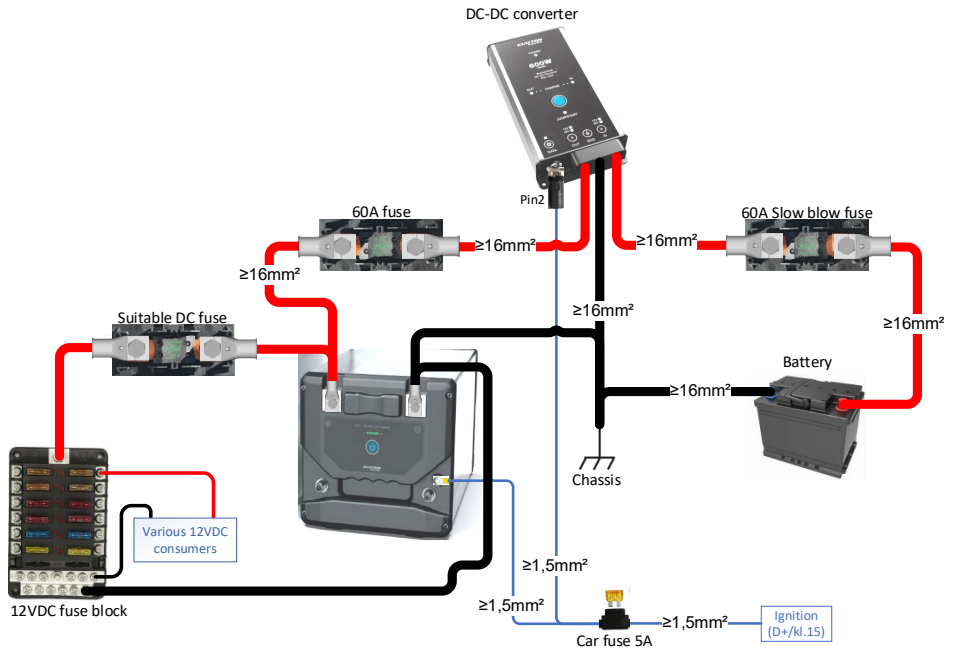

**WARNING:** Output fuse and cable size, including the grounding cable, should be rated according to the load being used.

**WARNING:** Using the wrong cable size or a bad cable connection can cause overheating and a short circuit.

**WARNING:** Place fuses as close as possible to the power source to prevent high current short-circuits.



If the LPS is used to run heavy equipment that requires constant high power, a larger DC-DC converter can be used to enable power transfer between the batteries and the LPS to keep up with the consumption. Using PN: **CD1804**, the power transfer is limited to 45 A, while PN: **CD2412** allows power transfer up to 90 A.

The installation using PN: **CD2412** is illustrated in the following diagram.

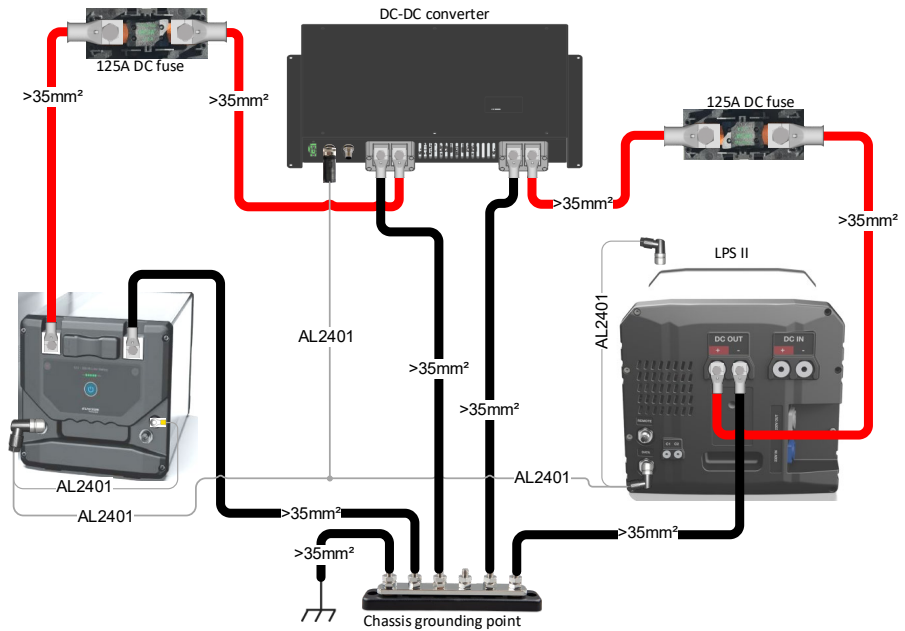

**WARNING:** Using the wrong cable size or a bad cable connection can cause overheating and a short circuit.

**WARNING:** Place fuses (max. 125 A) as close as possible to the power source to prevent high current short-circuits.

The communication / signal harness for both configurations is the same and is premade (PN: **AL2401**) and is constructed according to following table:

Description	Data LPS Front (Pin #)	Data DCDC (Pin #)	Data Li-G4 (Pin #)	Wake-up Li-G4	Data LPS Back (Pin #)
Charge	2	1	-	-	-
Discharge	-	2	2	-	2
GND	-	3	3	-	3
CAN High	-	4	4	-	4
CAN Low	-	5	5	-	5
Wake-up	-	-	2	Terminal	-

## 2.4 System configuration – Battery w. Combi

The Li-G4 can be used with a G3 Combi for 230 VAC applications.

Using a Clayton Power DC-DC converter between the Li-G4 and the vehicle battery allows charging during driving.

Connect the positive DC from the Li-G4 to the OUT terminal of the DC-DC converter, and the positive DC from the vehicle battery/accumulator to the IN terminal.

The battery can be charged using the Combi (Blue Neutrik) or from an accumulator.

With a remote connected, it is possible to turn on the AC output of the G3 combi and to activate the jump start function. Once activated, the jumpstart will charge the starter battery for 5 min with 40 A.

If not remote is used, the Li-G4 must be turned on/off with the power button on the front.

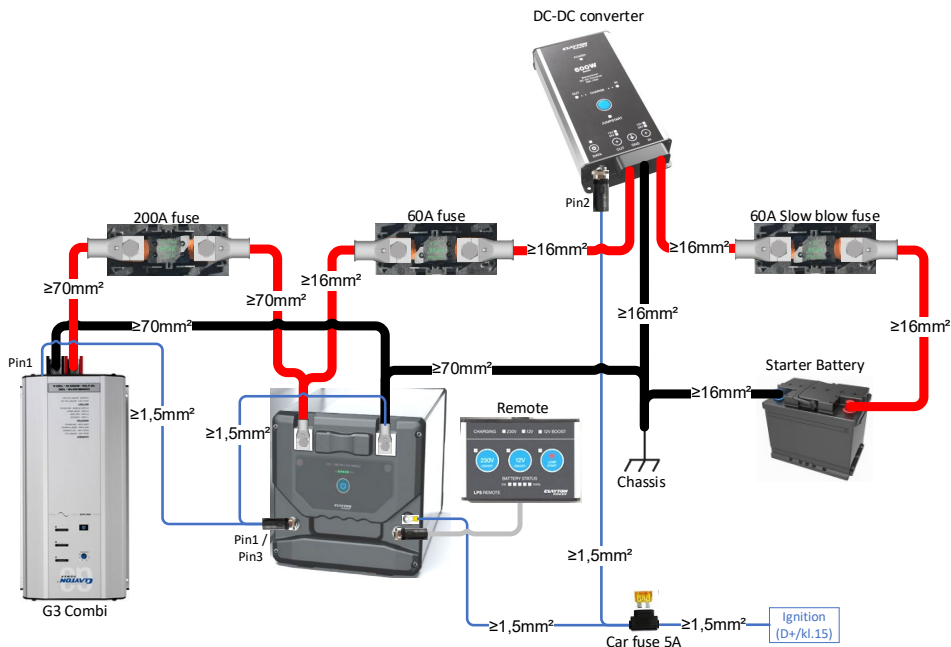

Wire the communications / control signals according to following table:

Description	Data Combi (Pin #)	Data Li-G4 (Pin #)	Neg. Term. Li-G4	Wake-up Li-G4	Data DCDC (Pin #)
Single Wire	1	1	-	-	-
Wake-up	-	-	-	Terminal	2
GND	-	3	Terminal	-	-

**WARNING:** Using the wrong cable size or a bad cable connection can cause overheating and a short circuit.

**WARNING:** Place fuses as close as possible to the power source to prevent high current short-circuits.

## 3. TROUBLESHOOTING

### 3.1 Error List

The battery uses its LEDs for error indication.

The following error list shows the cause of failure and how to solve the error.

If the solutions provided below are unable to resolve the error or if the error code is not listed, contact your retailer.

Flashes	Description	Solution
2	Unit temperature out of range	Let the device warm up / cool down or move it to a place with a higher / lower ambient temperature
3	Overload, Short Circuit or Pre-charge failure	Disconnect the load and restart the battery to confirm operation. Check for short circuits in installation or defective connected equipment
4	IO Terminal is overloaded or is short circuited	Disconnect connector and check connector or cable for damage
5	Blown internal fuse or defective internal switch	Contact your retailer for assistance
6	Other failures	Contact your retailer for assistance

Errors can be cleared by turning the battery off and on, depending on the type of error.

## 4. SPECIFICATIONS

Parameter	Li-G4 100Ah S2	Li-G4 280Ah S2
<b>General</b>		
Model no.	CB2301	CB2303
Type	Rechargeable Lion battery system	
Chemistry	LiFePO4	
Number of cells	4	
Cooling	Passive	
Ambient temperature discharge	-20 – 50 °C	
Ambient temperature charge	0 – 50 °C	
IP classification	54	
Marking (IEC 61960)	4IFpP51/161/119	4IFpP73/175/208
Marking (IEC 62620)	IFpP/51/161/119/[4S]M/- 20+50/90	IFpP/73/175/208/[4S]M/- 30+50/90
Parallel connection	Supported (only with LPS II)	
Serial connection	Not supported	
Maximum altitude	2000 m	
Product weight	12 kg	28 kg
Product size (H x W x L)	187 x 197 x 343 mm	243 x 197 x 438 mm
<b>Electrical</b>		
Capacity	100 Ah (1280 Wh)	280 Ah (3584 Wh)
Available capacity	80 Ah (1024 Wh)	235 Ah (3008 Wh)
Nominal voltage	12.8 V	
Operation voltage	10.8 - 14.4 V	
Discharge current - Continuous	175 A	200 A
Discharge current - 1 min.	400 A	
Charging current - Continuous	100 A	140 A
Cycle Life (80 %DOD)	> 2800 cycles (EOL = 60 %) 0.75C charge 1.75C discharge	> 2800 cycles (EOL = 70 %) 0.3C charge 0.5C discharge
Operating mode self-consumption	< 45 mA	
Sleep mode self-consumption	1.5 mA	
<b>I/O</b>		
Communication	CAN Bus (SAE J1939)	
I/O ports	2 x I/O and 1 x Input	
I/O input voltage	0 – 60 V	
I/O output voltage	0 – 12 V	
I/O output current	400 mA (Over current protected)	
I/O connector type (M12)	Type A – 5-way	
I/O connector type (Terminal)	M4	
<b>Battery management</b>		
Overvoltage warning for each cell	3.57 V	
Overvoltage protection for each cell	3.63 V	
Overvoltage release for each cell	3.52 V	
Undervoltage warning for each cell	2.70 V	
Undervoltage protection for each cell	2.50 V	
Undervoltage release for each cell	2.80 V	
Recovery method	Automatically when cell voltages are within limits	
Cell balancing method	Passive Balancing	
Cell balancing current	1 A	
Charge overcurrent protection	> 100 A	> 140 A
Discharge overcurrent protection	> 175 A	> 200 A
Over temperature protection each cell	55 °C	
Under temperature protection each cell for discharge	-20 °C	
Under temperature protection each cell for charge	0 °C	

**NOTE:** The Li-G4 will not charge correctly at temperatures below 0 °C, and charging at temperatures below 0 °C can damage the battery cells.

**NOTE:** The available power is reduced at an increasing rate for temperatures below 0°C.

## 5. CHARGE PROFILE AND SETTINGS

The recommended charging parameters for the charging sources are:

- **Li-G4 2S (100 Ah):** 50 A constant current (Max. 100 A - 1 cycle/day), 14.4 V constant voltage.
- **Li-G4 2S (280 Ah):** 56 A constant current (Max. 140 A - 1 cycle/day), 14.4 V constant voltage.

For more information on the charge settings of the individual chargers or inverters/chargers, please refer to the manuals on the respective product page.

**UNIT MUST BE CHARGED  
EVERY 6 MONTHS IF NOT  
USED**

## 6. SAFETY

The following measures ensure the safe and secure operation of the electrical system. Not following these measures can result in dangerous situations causing harm to the user and the equipment.

### 6.1 Internal Measures

- Correct orientation - Do not place the battery upside down.
- Incorrect cable size or bad cable connection can cause thermal issues or short circuits.
- Make sure the Li-G4 battery is turned off before starting the installation and do not connect any active wakeups before the installation is finished.
- Do not combine Li-G4 batteries with other brands.
- Battery operation is monitored by the battery management system to ensure safe operation. The integrated battery management system disconnects the power line in case of any abnormalities.

**ATTENTION:** DC terminals are protected with 400 A fuse in Li-G4 2S. The internal fuse cannot be replaced by user and requires service. Place a correctly dimensioned fuse as close as possible to the Li-G4 to prevent high current short-circuits and internal fuse blowing.

### 6.2 External Fuses

- All fuses must be installed as close to the power source as possible.
  - Measures must be taken to ensure the cable located between the fuse and the power source is laid out in a short-circuit-proof manner.
- Fuses should be clearly marked with their name and size.
- It is important to use fuses rated for DC voltages.
- MEGA fuses (recommended fuse type) should be mounted in holders.

### 6.3 Cables

- Cables need to be flexible.
  - Cables are rated in different classes related to flexibility.
  - Cables with classification 5 or 6 needs to be used (This cable type is also referred to as HIGH-FLEX)
- Cables are dimensioned according to the fuse size.
- Always use the designated connection points in the vehicle for chassis and DC connections (if available/indicated).
- Always route cables the shortest way possible.
- Cables should always be secured along the routing to ensure that it does not move unintentionally.
- Cable must be kept away from moving parts.
- When passing through bulkheads or other surfaces the cable needs to be guarded against chamfering.
  - This can be done by grinding the hole to eliminate sharp edges, using a rubber grommet within the hole and using conduit or tubing to shield the cable.
- Cable terminals should be used for the right cable cross section as they are made for.
- It is important to choose cable terminals for the right cable classification.
  - This means that classification 5 cables need a classification 5 terminal.
- When connecting the cable remember to use the right torque.
  - M8 bolts must be torqued to 12 Nm
  - M4 bolts must be torqued to 2.5 Nm
- When connecting the cable remember to use both spring and straight washer.

## 7. CERTIFICATIONS AND COMPLIANCE

**Low Voltage Directive 2014/35/EU**  
EN62133

**RoHS Directive 2011/65/EU**  
EN 63000

**EMC 2014/30/EU**  
EN61000-6-2, EN61000-6-3

**E-Marking**  
UN-ECE Regulation 10, E5 10R06/03 0703 00  
(100 Ah)  
UN-ECE Regulation 10, E5 10R06/03 0702 00  
(280 Ah)

## 8. BATTERY MAINTENANCE

To ensure optimal battery performance, fully recharge the battery every month (100 %).

To prevent deep discharge of the batteries, it will go into Sleep Mode when the SOC is below 0%.

When in Sleep Mode the battery uses a very low amount of power and can last for up to 2 years without being charged.

The Sleep Mode can also be entered manually by holding down the power button for 10 seconds until the LEDs start to blink rapidly.

If the Sleep Mode has been entered, the battery will wake up when the power button is pushed (and hold for 1 second), if the wake signal goes high or if a voltage is applied to the battery terminals of more than 13.5 V.

The wakeup source is disabled if the function had failures when the LPS entered Sleep Mode.

**NOTE:** Sleep mode is available for units with software version 01:00:04 or higher.

**NOTE:** If the battery has not been fully charged for a long period, maintenance charge can be prolonged up to 3 days.

**UNIT MUST BE CHARGED  
EVERY 6 MONTHS IF NOT  
USED**

## 9. STORAGE

The battery can be stored at temperatures between -20 °C and 50 °C. For long term storage (>1 month), the battery should be fully charged and stored at temperatures between 0 °C and 35 °C. Do not store the battery upside down.

## 10. TRANSPORTATION

Lithium batteries are classified as Class 9 hazardous materials (UN3480) and must always be transported in compliance with all applicable local, national, and international regulations. Proper packaging is required during transportation, and packaging instructions (PI965) must be respected. The batteries should not be turned upside down during transportation.

## 11. DISPOSAL

To ensure proper disposal and reduce potential hazards, discharge the battery completely before placing it in a designated battery recycling bin. Improper disposal, such as throwing it in regular rubbish bins, is strictly prohibited as the product contains batteries with potentially harmful chemicals. Adhere to local laws and regulations for battery recycling and disposal.

## 12. WARRANTY

### **IMPORTANT AND WARNING:**

**DO NOT USE OR ATTEMPT TO USE THIS PRODUCT UNTIL YOU HAVE READ THE USER MANUAL IN ITS ENTIRETY. IMPROPER INSTALLATION OR USE OF THIS DEVICE MAY BE DANGEROUS AND MAY CAUSE DAMAGE TO OTHER ELECTRICAL EQUIPMENT AND WILL VOID THE WARRANTY.**

**Warranty.** The company guarantees that products and associated services are free of significant defects in design, material and execution for 24 months after delivery.

**Exceptions.** The company's warranty does not include defects caused by: (i) ordinary wear and tear, (ii) storage, installation, use or maintenance against the company's instructions or ordinary practice, (iii) repair or change carried out by others than the company, and (iv) other conditions for which the company has no responsibility.

**Examination.** Within a reasonable period of time after receiving a complaint from the client about defects and examining the claim, the company will inform the client about whether or not the defects are covered by the warranty. After the request, the client must ship defective parts to the company. The client covers the expenses and risks of the parts during transport to the company. The company covers the expenses and risks for return of parts during transport, only if the defects are covered by the warranty.

**Register a complaint.** If the client discovers defects within the period of warranty, which the client wishes to invoke, it must be communicated immediately in writing. If defects, which the client discovers or should have discovered, are not immediately communicated to the company in writing, it cannot be effectuated at a later time. The client must provide the company with the requested information about the defects registered.

### **Instructions for Obtaining Warranty Service for Clayton Power Devices**

To obtain warranty service, contact the store where you have bought the product and provide the following:

- Sales receipt
- Device model number
- Device serial number
- Brief description of the application and problem, including any error codes displayed on the device.
- Obtain an authorisation number from the Clayton Power dealer before shipping the device. Carefully pack the device and ship it (freight paid) to the Clayton Power dealer. Note that the device contains lithium batteries and must be shipped as dangerous goods according to UN3480 lithium-ion batteries' regulations.

**Sales:** [sales@claytonpower.com](mailto:sales@claytonpower.com)

**Service:** [service@claytonpower.com](mailto:service@claytonpower.com)

**Phone:** +45 4698 5760

**Address:** Pakhusgaarden 42-48  
DK-5000 Odense C



**CLAYTON**  
**POWER**